

HMC Series Dual Displacement Staffa Motor

Staffa

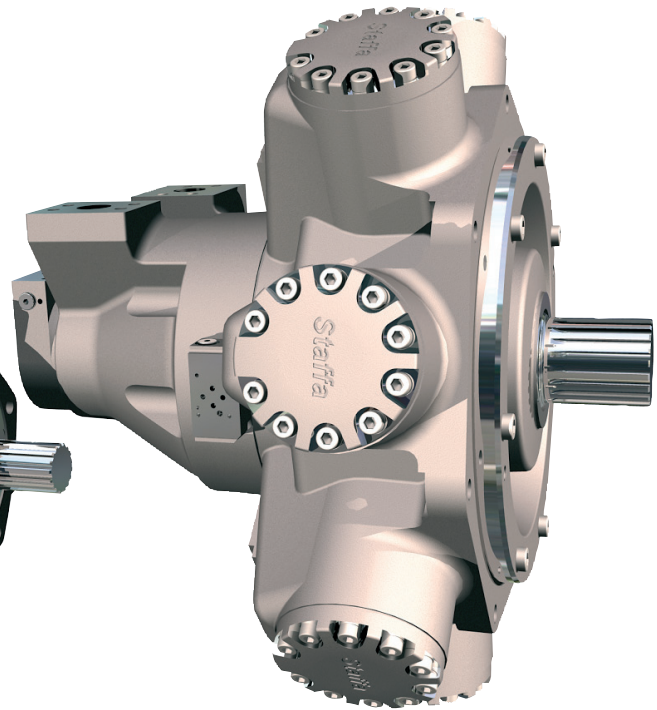

Description

The range of dual displacement motors extends from the HMC030 in 492cc/rev. to the HMC325 in 5326cc/rev.

There are seven frame sizes as shown in the table below:

Motor Type	Max. torque @ 275 bar (Nm)	Continuous shaft power (kW)
HMC030	1655 **	60
HMC045	2930	99
HMC080	6560	138
HMC125	8220	135
HMC200	12820	174
HMC270	19090	189
HMC325	22110	189

**Torque calculated at 241 bar.

Key Features

- High torque at low speed
- Smooth running
- Wide range of displacements to suit specific applications
- Displacement changes with ease when the motor is running
- Electro-hydraulic or hydro-mechanical control methods available
- Various mounting options available
- Speed sensing options
- Motor mounted manifold options

Performance data	3
Volumetric efficiency data	11
Shaft power calculation	12
Functional symbols	13
Displacement control options	14
Constant pressure valve (CP)	16
Motor mounted manifold packages	19
Shaft stress limits	24
Bearing life notes	25
Circuit and application notes	26
Motor operation at low temperature	29
Freewheeling notes	30
Installation data	31
Crankcase drain connections	32
HMC030 shaft options	33
HMC045 shaft options	34
HMC080 shaft options	35
HMC125 shaft options	36
HMC200 shaft options	37
HMC270/325 shaft options	38
HMC030 installation	39
HMC045 installation	41
HMC080 installation	43
HMC125 installation	45
HMC200 installation	47
HMC270 installation	49
HMC325 installation	51
Main port connections	53
Speed sensing options	54
Ordering code	57

Kawasaki "Staffa" high torque, low speed radial piston motors use hydrostatic balancing techniques to achieve high efficiency, combined with good breakout torque and smooth running capability.

The HMC series dual displacement models have two pre-set displacements which can be chosen from a wide range to suit specific application requirements. The displacements are hydraulically selected by a directional control valve which can be remote mounted or directly on the motor. Motor displacement can be changed with ease when the motor is running.

These motors are also available in a continuously variable version using either hydro-mechanical or electro-hydraulic control methods.

Other mounting options are available on request to match many of the competitor interfaces.

Note: To order the HPC series motor refer to bulletin data sheet M-1003

Performance data is valid for the range of HMC motors when fully run-in and operating with mineral oil.

The appropriate motor displacements can be selected using performance data shown on pages 4 to 10. Refer to the table on this page for pressures and speed limits when using fire-resistant fluids.

Limits for fire resistant fluids

FLUID TYPE	CONTINUOUS PRESSURE (bar)	INTERMITTENT PRESSURE (bar)	MAX SPEED (rpm)	MODEL TYPE
HFA 5/95 oil-in-water emulsion	130	138	50% of limits of petroleum oil	All models
HFB 60/40 water-in-oil emulsion	138	172	As for petroleum oil	All models
HFC water glycol	103	138	50% of limits of petroleum oil	All models
HFD phosphate ester	250	275	As for petroleum oil	All models

Specify make and type of fluid on your order if other than petroleum oil.

Rating definitions

Continuous rating

The motor must be operated within each of the maximum values for speed, pressure and power.

Intermittent pressure rating

Intermittent max pressure: 275 bar.

This pressure is allowable on the following basis:

- (a) Upto 50 rpm 15% duty for periods upto 5 minutes maximum.
- (b) Over 50 rpm 2% duty for periods upto 30 seconds maximum.

Static pressure to DNV rules 380 bar.

Intermittent power rating

This is permitted on a 15% duty basis for periods upto 5 minutes maximum.

HMC030 Motor (See page 12 for power calculation limits)

Displacement Code		30	27	24	21	18	15
Displacement	cc/rev	492	442	393	344	295	246
Average actual running torque	Nm/bar	6.86	6.08	5.3	4.59	3.88	3.2
Average actual mechanical efficiency	%	87.6	86.4	84.7	83.8	82.6	81.7
Average actual starting efficiency	%	82.8	81.4	79.6	77.1	73.9	69.3
Max continuous speed	rpm	450	500	525	550	575	600
Max continuous power	kW	60	60	55	49	42	35
Max intermittent power	kW	66	66	61	55	48	41
Max continuous pressure	bar	207	207	207	207	207	207
Max intermittent pressure	bar	241	241	241	241	241	241

Displacement Code		12	09	06	03	00	00
Displacement	cc/rev	197	147	98	49	0	0
Average actual running torque	Nm/bar	2.51	1.83	1.15	0.44	0	0
Average actual mechanical efficiency	%	80.1	78.2	73.7	56.4	0	0
Average actual starting efficiency	%	62.6	51.6	29.1	/	/	/
Max continuous speed	rpm	600	600	600	600	1000	1500**
Max continuous power	kW	27	20	10	0	0	0
Max intermittent power	kW	32	24	13	0	0	0
Max continuous pressure	bar	207	207	207	17*	17*	17*
Max intermittent pressure	bar	241	241	241	17*	17*	17*

Data shown is at 207 bar. Intermediate displacements can be made available to special order.

* See page 26: small displacements.

** A crankcase flushing flow of 15 lpm is required when freewheeling at 1500 rpm.

HMC045 Motor *(See page 12 for power calculation limits)*

Displacement Code		45	40	35	30	25	20
Displacement	cc/rev	737	655	573	492	410	328
Average actual running torque	Nm/bar	10.63	9.4	8.04	6.88	5.68	4.4
Average actual mechanical efficiency	%	90.6	90.2	88.2	87.9	87.0	84.3
Average actual starting efficiency	%	84.5	83.0	81.1	78.4	74.9	69.5
Max continuous speed	rpm	450	550	600	600	600	600
Max continuous power	kW	99	89	79	67	54	42
Max intermittent power	kW	119	107	95	80	65	50
Max continuous pressure	bar	250	250	250	250	250	250
Max intermittent pressure	bar	275	275	275	275	275	275

Displacement Code		15	10	5	00	00
Displacement	cc/rev	246	163	81	0	0
Average actual running torque	Nm/bar	3.2	1.55	0	0	0
Average actual mechanical efficiency	%	81.7	59.7	0	0	0
Average actual starting efficiency	%	60.6	43.0	/	/	/
Max continuous speed	rpm	600	600	1000	1000	1500**
Max continuous power	kW	30	15	0	0	0
Max intermittent power	kW	36	18	0	0	0
Max continuous pressure	bar	250	250	17*	17*	17*
Max intermittent pressure	bar	275	275	17*	17*	17*

Data shown is at 250 bar. Intermediate displacements can be made available to special order.

* See page 26: small displacements.

** A crankcase flushing flow of 15 lpm is required when freewheeling at 1500 rpm.

HMC080 Motor (See page 12 for power calculation limits)

Displacement Code		97.6	90	85	80	75	70	65	60	55	50
Displacement	cc/rev	1600	1475	1393	1311	1229	1147	1065	983	901	819
Average actual running torque	Nm/bar	23.9	22	20.75	19.5	18.25	17.02	15.78	14.55	13.2	12
Average actual mechanical efficiency	%	93.9	93.7	93.6	93.5	93.3	93.2	93.1	93.0	92.1	92.1
Average actual starting efficiency	%	87.1	86.0	85.2	84.3	83.3	82.1	80.8	79.2	77.4	75.1
Max continuous speed (SO3/F3/FM3)	rpm	270	300	320	340	365	390	420	450	475	500
Max continuous speed (SO4/F4/FM4)	rpm	365	400	415	430	445	460	475	490	500	515
Max continuous power	kW	138	138	134	129	127	123	118	115	110	105
Max intermittent power	kW	170	170	165	159	156	151	145	142	135	129
Max continuous pressure	bar	250	250	250	250	250	250	250	250	250	250
Max intermittent pressure	bar	275	275	275	275	275	275	275	275	275	275

Displacement Code		45	40	35	30	25	20	15	10	5	00	00
Displacement	cc/rev	737	655	574	492	410	328	246	164	82	0	0
Average actual running torque	Nm/bar	10.6	9.24	7.87	6.48	5.31	3.93	2.56	1.57	0	0	0
Average actual mechanical efficiency	%	90.4	88.6	86.1	82.8	81.4	75.3	65.4	60.2	0	0	0
Average actual starting efficiency	%	72.4	69.0	64.4	58.6	50.3	38.0	17.5	/	/	/	/
Max continuous speed (SO3/F3/FM3)	rpm	550	600	615	630	630	630	630	630	1000	1000	1500**
Max continuous speed (SO4/F4/FM4)	rpm	530	545	560	575	585	600	615	630	1000	1000	1500**
Max continuous power	kW	99	92	79	64	52	38	26	12	0	0	0
Max intermittent power	kW	122	113	97	79	64	47	32	15	0	0	0
Max continuous pressure	bar	250	250	250	250	250	250	250	250	17*	17*	17*
Max intermittent pressure	bar	275	275	275	275	275	275	275	275	17*	17*	17*

Data shown is at 250 bar. Intermediate displacements can be made available to special order.

* See page 26: small displacements. ** A crankcase flushing flow of 15 lpm is required when freewheeling at 1500 rpm.

HMC125 Motor (See page 12 for power calculation limits)

Displacement Code		125	120	110	100	90	80	70	60	50	40
Displacement	cc/rev	2048	1966	1802	1639	1475	1311	1147	983	819	655
Average actual running torque	Nm/bar	29.9	28.7	26.3	23.6	21	18.3	15.7	12.8	10.6	8.1
Average actual mechanical efficiency	%	91.7	91.7	91.7	90.5	89.5	87.7	86.0	81.8	81.3	77.7
Average actual starting efficiency	%	80.2	79.2	77.0	74.3	71.1	67.0	61.8	54.9	45.2	30.6
Max continuous speed (SO3/F3/FM3)	rpm	215	225	240	270	300	340	390	450	500	600
Max continuous speed (SO4/F4/FM4)	rpm	300	310	340	365	400	430	460	490	515	545
Max continuous power	kW	135	131	122	114	105	98	88	81	72	62
Max intermittent power	kW	152	147	137	128	118	110	99	91	81	70
Max continuous pressure	bar	250	250	250	250	250	250	250	250	250	250
Max intermittent pressure	bar	275	275	275	275	275	275	275	275	275	275

Displacement Code		30	20	10	5	00	00
Displacement	cc/rev	492	328	164	82	0	0
Average actual running torque	Nm/bar	5.9	3.8	0.6	0	0	0
Average actual mechanical efficiency	%	75.3	72.8	23.0	0	0	0
Average actual starting efficiency	%	/	/	/	/	/	/
Max continuous speed (SO3/F3/FM3)	rpm	630	630	630	1000	1000	1500**
Max continuous speed (SO4/F4/FM4)	rpm	575	600	630	1000	1000	1500**
Max continuous power	kW	48	24	4	0	0	0
Max intermittent power	kW	54	33	6	0	0	0
Max continuous pressure	bar	250	250	250	17*	17*	17*
Max intermittent pressure	bar	275	275	275	17*	17*	17*

Data shown is at 250 bar. Intermediate displacements can be made available to special order.

* See page 27: small displacements. ** A crankcase flushing flow of 15 lpm is required when freewheeling at 1500 rpm.

HMC200 Motor *(See page 12 for power calculation limits)*

Displacement Code		188	180	170	160	150	140	130	120	110	100
Displacement	cc/rev	3087	2950	2790	2620	2460	2290	2130	1970	1800	1639
Average actual running torque	Nm/bar	46.6	44	41.7	39.1	36.6	34	31.3	28.7	26.3	23.6
Average actual mechanical efficiency	%	94.8	93.7	93.9	93.8	93.5	93.3	92.3	91.5	91.8	90.5
Average actual starting efficiency	%	85.4	84.9	83.9	83.1	81.8	80.7	79.1	77.2	75.4	72.8
Max continuous speed (SO3/F3/FM3)	rpm	175	180	190	195	200	205	210	225	240	270
Max continuous speed (SO4/F4/FM4)	rpm	230	235	240	245	250	265	285	310	340	365
Max continuous power	kW	174	174	174	165	156	148	139	131	122	114
Max intermittent power	kW	195	195	195	185	175	166	156	147	137	128
Max continuous pressure	bar	250	250	250	250	250	250	250	250	250	250
Max intermittent pressure	bar	275	275	275	275	275	275	275	275	275	275

Displacement Code		90	80	70	60	50	40	30	20	10	5	00	00
Displacement	cc/rev				983	820	655	492	328	164	82	0	0
Average actual running torque	Nm/bar	21	18.3	15.7	12.8	10.6	8.1	5.9	3.8	0.6	0	0	0
Average actual mechanical efficiency	%	89.5	87.7	85.8	81.8	81.2	77.7	75.3	72.8	23.0	0	0	0
Average actual starting efficiency	%	69.8	66.1	61.1	54.8	45.7	32.1	/	/	/	/	/	/
Max continuous speed (SO3/F3/FM3)	rpm	300	340	390	450	500	600	630	630	630	1000	1000	1500**
Max continuous speed (SO4/F4/FM4)	rpm	400	430	460	485	515	545	575	600	630	1000	1000	1500**
Max continuous power	kW	105	98	88	81	72	62	48	25	5	0	0	0
Max intermittent power	kW	118	110	99	91	81	70	54	33	6	0	0	0
Max continuous pressure	bar	250	250	250	250	250	250	250	250	250	17*	17*	17*
Max intermittent pressure	bar	275	275	275	275	275	275	275	275	275	17*	17*	17*

Data shown is at 250 bar. Intermediate displacements can be made available to special order.

* See page 26: small displacements. ** A crankcase flushing flow of 15 lpm is required when freewheeling at 1500 rpm.

HMC270 Motor (See page 12 for power calculation limits)

Displacement Code		280	250	220	200	180	160	140	120	100	80
Displacement	cc/rev	4588	4097	3605	3277	2950	2622	2294	1966	1639	1311
Average actual running torque	Nm/bar	69.4	61.9	53.9	49	43.6	38.3	33.2	27.9	22.4	17.1
Average actual mechanical efficiency	%	95.0	94.9	93.9	94.0	92.9	91.8	90.9	89.2	85.9	82.0
Average actual starting efficiency	%	84.7	83.8	82.7	81.8	80.6	79.2	77.3	74.9	71.5	66.3
Max continuous speed	rpm	150	160	170	175	210	230	275	310	375	430
Max continuous power	kW	189	176	161	150	139	128	116	104	89	73
Max intermittent power	kW	213	198	181	169	156	144	132	120	107	95
Max continuous pressure	bar	250	250	250	250	250	250	250	250	250	250
Max intermittent pressure	bar	275	275	275	275	275	275	275	275	275	275

Displacement Code		60	40	30	20	10	00	00
Displacement	cc/rev	983	655	492	328	164	0	0
Average actual running torque	Nm/bar	12.2	7.9	5.15	2.4	0	0	0
Average actual mechanical efficiency	%	78.0	75.8	65.8	46.0	0	0	0
Average actual starting efficiency	%	57.8	40.7	23.5	/	/	/	/
Max continuous speed	rpm	460	490	515	545	1000	1000	1500**
Max continuous power	kW	57	38	26	14	0	0	0
Max intermittent power	kW	80	55	38	20	0	0	0
Max continuous pressure	bar	250	250	250	250	17*	17*	17*
Max intermittent pressure	bar	275	275	275	275	17*	17*	17*

Data shown is at 250 bar. Intermediate displacements can be made available to special order.

* See page 26: small displacements. ** A crankcase flushing flow of 15 lpm is required when freewheeling at 1500 rpm.

HMC325 Motor *(See page 12 for power calculation limits)*

Displacement Code		325	310	300	280	250	220	200	180	160	140
Displacement	cc/rev	5326	5080	4916	4588	4097	3605	3277	2950	2622	2294
Average actual running torque	Nm/bar	80.4	76.6	74.1	69.1	61.6	53.9	49	43.6	38.3	33.2
Average actual mechanical efficiency	%	94.8	94.7	94.7	94.6	94.5	93.9	94.0	92.9	91.8	90.9
Average actual starting efficiency	%	85.7	85.4	85.2	84.7	83.8	82.7	81.8	80.6	79.2	77.3
Max continuous speed	rpm	130	135	140	150	160	170	190	215	230	275
Max continuous power	kW	189	189	189	189	176	161	150	139	128	116
Max intermittent power	kW	213	213	213	213	198	181	169	156	144	132
Max continuous pressure	bar	250	250	250	250	250	250	250	250	250	250
Max intermittent pressure	bar	275	275	275	275	275	275	275	275	275	275

Displacement Code		120	100	95	80	60	40	30	20	10	00	00
Displacement	cc/rev	1966	1639	1557	1311	983	655	492	328	164	0	0
Average actual running torque	Nm/bar	27.9	22.4	20.9	17.1	12.2	7.9	5.15	2.4	0	0	0
Average actual mechanical efficiency	%	89.2	85.9	84.3	82.0	78.0	75.8	65.8	46.0	0	0	0
Average actual starting efficiency	%	74.9	71.5	70.4	66.3	57.8	40.7	23.5	/	/	/	/
Max continuous speed	rpm	330	370	405	440	460	495	515	545	1000	1000	1500**
Max continuous power	kW	104	89	85	73	57	38	26	14	0	0	0
Max intermittent power	kW	120	107	101	95	80	55	38	20	0	0	0
Max continuous pressure	bar	250	250	250	250	250	250	250	250	17*	17*	17*
Max intermittent pressure	bar	275	275	275	275	275	275	275	275	17*	17*	17*

Data shown is at 250 bar. Intermediate displacements can be made available to special order.

* See page 26: small displacements.

** A crankcase flushing flow of 15 lpm is required when freewheeling at 1500 rpm.

MOTOR TYPE	GEOMETRIC DISPLACEMENT	ZERO SPEED CONSTANT	SPEED CONSTANT	CREEP SPEED CONSTANT	CRANKCASE LEAKAGE CONSTANT	FLUID VISCOSITY cSt	VISCOSITY FACTOR Kv
HMC	cc/rev	K₁	K₂	K₃	K₄	20	1.58
HMC030	492	4.9	*	10	3.5	25	1.44
HMC045	737	6.6	47.8	8.5	4	30	1.3
HMC080	1639	9.5	45.7	5.8	7.9	40	1.1
HMC125	2048	6.1	38.5	3	4.25	50	1
HMC200	3087	6.1	38.5	2	4.25	60	0.88
HMC270	4310	6.5	37.3	1.5	6		
HMC325	5210	6.8	40	1.3	6		

Q_t (total leakage) = $[K_1 + n/K_2] \times \Delta P \times K_v \times 0.005$ (lpm)
 $*Q_t$ (C030) = $K_1 \times \Delta P \times K_v \times 0.005$ (lpm)
 Creep speed = $K_3 \times \Delta P \times K_v \times 0.005$ (rpm)
 Crankcase leakage = $K_4 \times \Delta P \times K_v \times 0.005$ (lpm)
 ΔP = differential pressure (bar)
 n = speed (rpm)

The motor volumetric efficiency can be calculated as follows:

$$\text{Volumetric efficiency (\%)} = \left[\frac{(\text{speed} \times \text{disp.})}{(\text{speed} \times \text{disp.}) + Q_t} \right] \times 100$$

Example:

HMC200 motor with displacement of 3.087 l/rev.

Speed 60 rpm
 Differential pressure 200 bar
 Fluid viscosity 50 cSt

Total leakage = $(K_1 + n/K_2) \times \Delta P \times K_v \times 0.005$ (lpm)
 = $(6.1 + 60/38.5) \times 200 \times 1 \times 0.005$
 = 7.7 (lpm)

Volume efficiency = $\left[\frac{(60 \times 3.087)}{(60 \times 3.087) + 7.7} \right] \times 100$
 = 96%

Example (see page 9):

HMC270 motor with a displacement code of 280:

Firstly, to find the maximum differential pressure ΔP at rated speed :

Rated shaft power (W): 189000
Average actual running torque (Nm/bar): 69.4
Rated shaft speed (rpm): 150

$$189000 = 69.4 \times \Delta P \times 150 \times 2 \times \pi / 60$$

$$\Delta P = 174 \text{ bar (max.)}$$

Secondly, to find the maximum speed at rated pressure :

Rated shaft power (W) : 189000
Average actual running torque (Nm/bar) : 69.4
Rated pressure (bar) : 250

$$189000 = 69.4 \times 250 \times n \times 2 \times \pi / 60$$

$$n = 104 \text{ rpm (max.)}$$

In summary, operating the motor within its shaft power limit, at rated speed, would give a maximum pressure of 174 bar, and operating the motor at rated pressure, would give a maximum speed of 104 rpm.

Notes :

1. The maximum calculated speed is based on a rated inlet pressure of 250 bar.
2. The maximum shaft power is only allowable if the motor drain temperature remains below 80°C.
3. The maximum calculated differential pressure assumes that the low pressure motor port is less than 30 bar.

Example model code:

HMC***/P/****/**/FM3/X/...

X - external pilot supply to 'X' and 'Y' ports

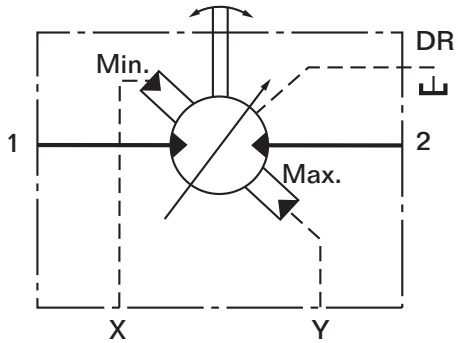

Example model code:

HMC***/P/****/**/FM3/C/...

C - single external supply to PC port

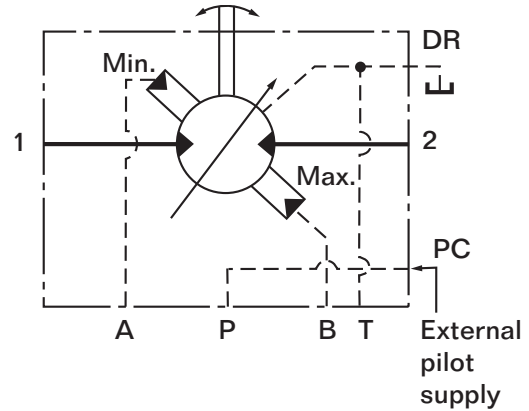

Example model code:

HMC***/P/****/**/FM3/CS/...

CS - internally shuttled pilot supply

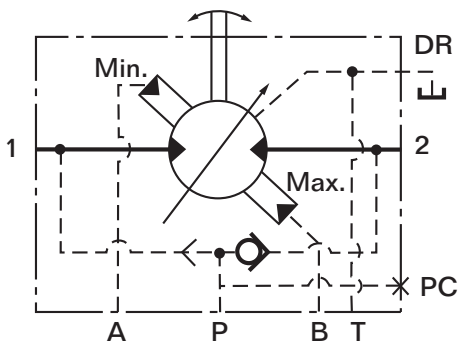

Example model code:

HMC***/P/****/**/FM3/C1/...

C1 - internal pilot supply from port 1 for clockwise rotation only

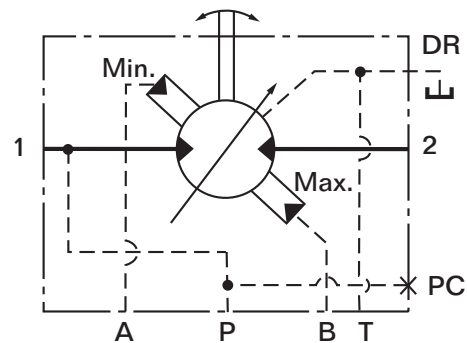

There is a single port (PC) in the 'C' spacer.

Pressure ports in FM3 & FM4 valve housings can be called up as special features when required.

Example model code - HMC200/S/180/FM4/X/71

Types: C, CS & C1

MOUNTING INTERFACE FOR DIRECTIONAL CONTROL VALVE*
 TO: ISO 4401 SIZE 03/ANSI B93.7M SIZE D03.
 *DISPLACEMENT SELECTOR VALVE IS NOT SUPPLIED WITH MOTOR; SPECIFY & ORDER SEPARATELY

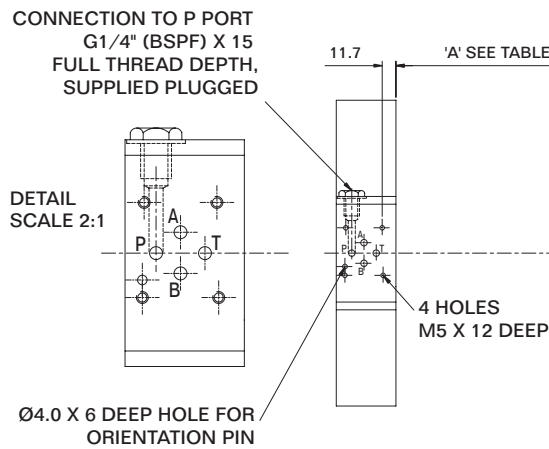

DISPLACEMENT SELECTION:
 HIGH DISPLACEMENT: P TO B; A TO T
 LOW DISPLACEMENT: P TO A; B TO T

MOUNTING FACE

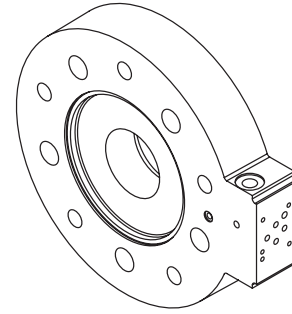

Frame Size	Dim 'A'	Dim 'B'
HMC030	159.0	/
HMC045	188.5	/
HMC080	173.5	477.0
HMC125	203.8	507.0
HMC200	216.4	520.0
HMC270	232.4	538.0
HMC325	232.4	538.0

Type: X

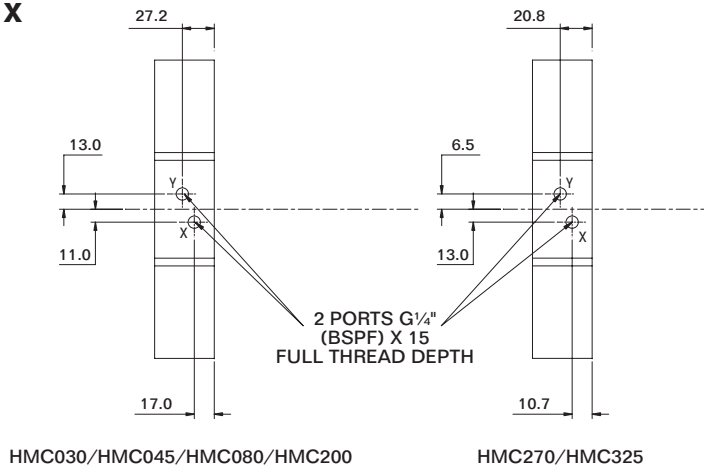

DISPLACEMENT SELECTION (VIA REMOTELY LOCATED VALVE*)
 HIGH DISPLACEMENT: P TO Y; X TO T
 LOW DISPLACEMENT: P TO X; Y TO T
 *DISPLACEMENT SELECTOR VALVE IS NOT SUPPLIED WITH MOTOR; SPECIFY & ORDER SEPARATELY

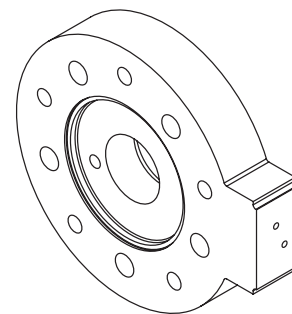

Example model code - HMC200/S/180/60/FM4/CS/71

MOUNTING FACE

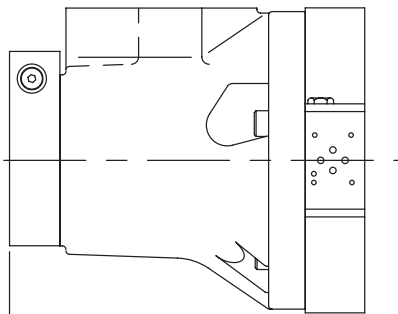

'B' SEE TABLE ON PAGE 14

**CS Type shuttle endcap on
F4 & FM4 assemblies only**

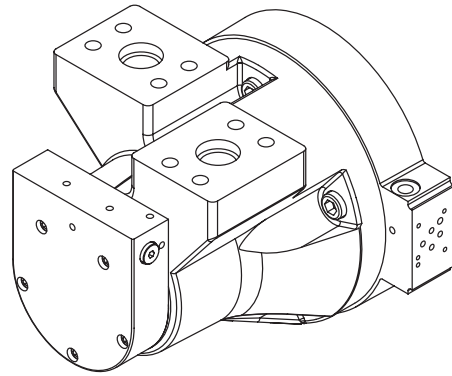

**CS Type shuttle on
F3 & FM3 assemblies only**

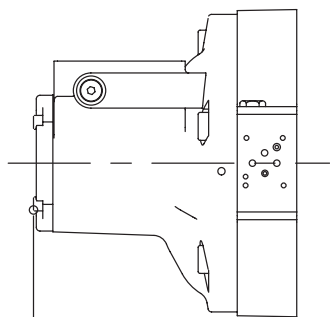

SEE VALVE HOUSING PAGE

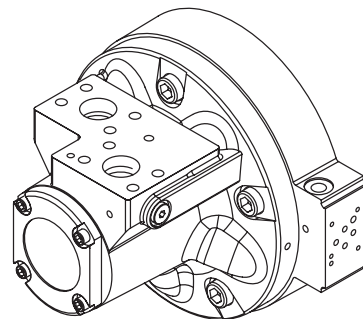

REFER TO CIRCUIT
DIAGRAM ON PAGE 13
FOR 'CS' C-SPACERS

Description

The constant power control uses the HMC series dual displacement motor with an improved crankshaft assembly and a motor mounted pressure sensing proportional valve. The advantage of such a system attempts to utilise all of the installed power and transfer it to the load. This results in either high torque low speed or low torque high speed operation of the load.

The motor displacement is dependent on load pressure and valve pressure setting. If the load pressure is below the valve pressure setting, then the displacement will change towards its minimum and if the load pressure is above the valve pressure setting, then the displacement will change towards its maximum.

The motor displacement will be set between its maximum and minimum limits when the valve setting pressure equals the load pressure. If the load pressure cannot achieve the valve setting pressure, then the motor will remain in its minimum displacement. If the load pressure continues to exceed the valve pressure setting, then the motor will remain in its maximum displacement and the load pressure will continue to increase to the system pressure limit.

The control system will seek to maintain the valve pressure setting when the motor is either motoring or pumping.

Constant motor input power is achieved when the motor operates at the valve pressure setting and the motor flow remains constant.

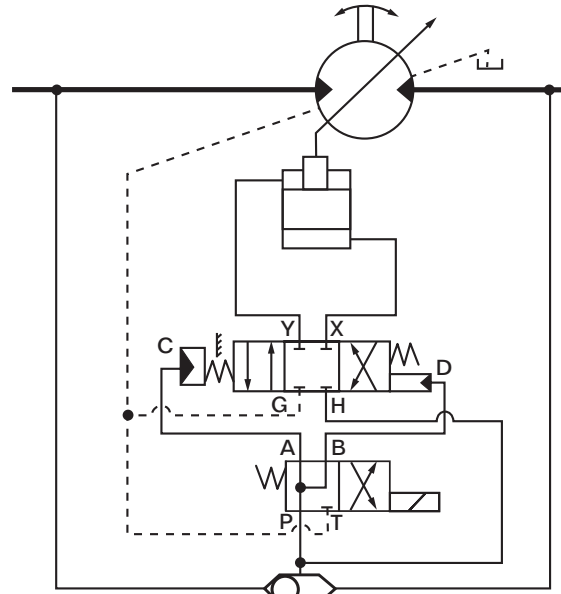

Fig. 1

Operation of constant pressure valve

The higher motor port pressure is shuttled to the H port on the CP valve and if the pressure level is below 7 bar, then the spool will move to the left, due to the bias spring, and port pressure from H to Y. This will select the motor maximum displacement or low speed operation.

As the motor pressure increases above 7 bar, pressure at port C will act on the nut adjusting piston and move the spool to the right until the nut contacts the CP valve body. The nut position sets the primary spring force and hence valve pressure setting. This will now select the motor to minimum displacement or low speed.

As the load pressure on the sensing pin area approaches the primary spring preload force, as determined by the adjuster nut position, the spool will now move proportionally to the left. This will connect port H to port Y and the motor displacement will increase until the pressure at port H reduces back to the CP valve pressure setting.

The spool position will continue to adjust the pressure at ports X and Y in a proportional manner to maintain a constant motor pressure.

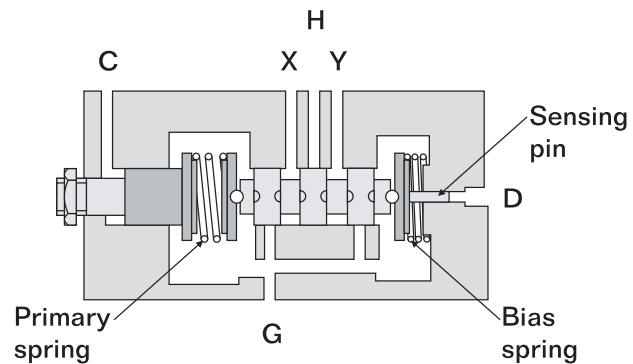

Fig. 2

Valve pressure setting

The constant pressure valve is factory set to give a motor inlet pressure of between 100 to 220 bar as specified by the customer. The actual valve pressure setting will depend on the following considerations: load speed characteristic, motor displacement range, speed range, motor mechanical efficiency in low displacement and load holding requirements. The effect of valve pressure setting can be seen in fig.3 whereby for a fixed motor inlet flow, the motor input power can be seen to increase with valve pressure setting.

Fig. 3 shows the corner power limit in a displacement of 40 cu.in. This assumes that the motor low pressure port is at 10 bar, giving a motor differential pressure of 190 bar. CP operation at the corner power is assumed to be an intermittent condition and therefore the intermittent power is allowed, see page 9. This sets the maximum shaft power at the valve pressure setting of 200 bar. If the motor inlet flow is maintained for an increase in load, then the motor shaft power will remain at a low level just above the corner power limit. To utilise the installed power, the motor inlet flow and load must now be increased in order to increase the motor shaft power and hence run on a higher power curve.

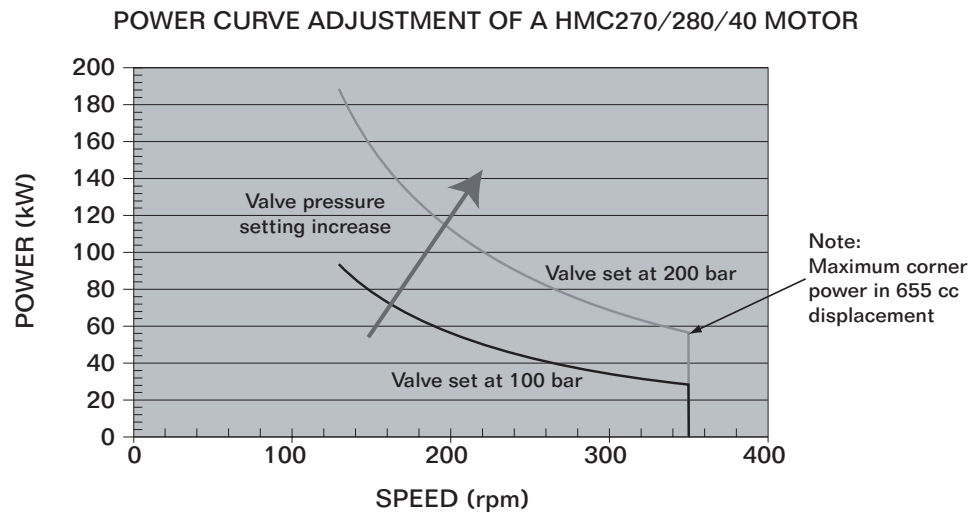

Fig. 3

Valve adjustment

A variable load pressure is used to factory set the valve pressure setting. The valve pressure adjustment without a variable load pressure can be difficult to set due to the very stiff adjustment spring. A 360 degree rotation of the adjusting nut will produce a pressure setting change of 200 bar. However, it is possible to adjust the valve pressure setting without load providing that before adjustment, the adjusting nut is marked with reference to the valve body, see fig.4.

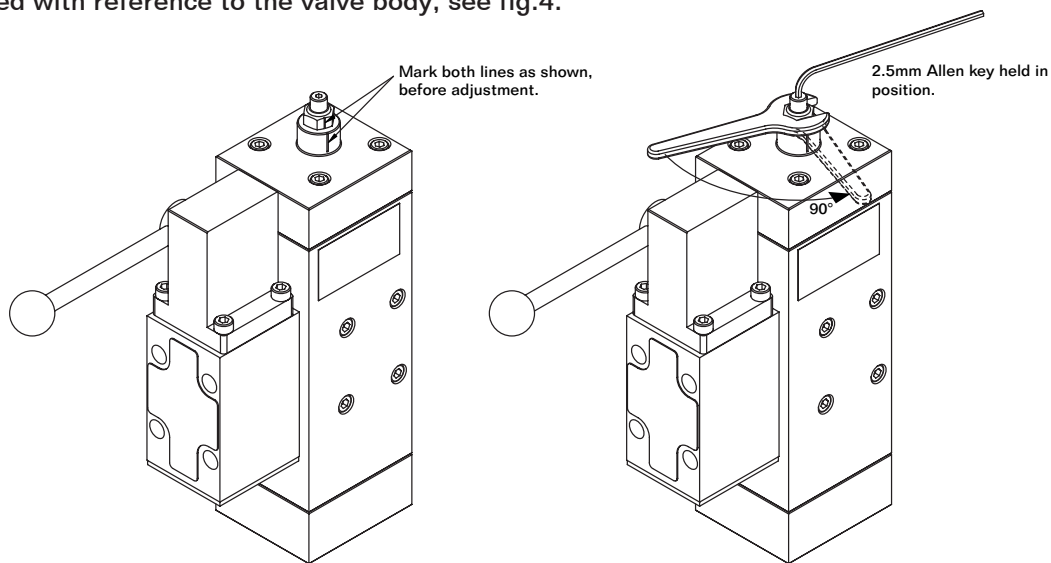

Fig. 4

Override valve selection

The constant pressure valve can be fitted with a CETOP3 override valve, which when activated moves the constant pressure valve spool in a direction to select maximum displacement. The override option is available with a lever operated or a solenoid activated valve, see fig.5 and fig.6.

Fig.6 includes the Tj speed sensor option, which when combined with the T401 module can be used to automatically select maximum displacement at a pre-set low speed (see page 56).

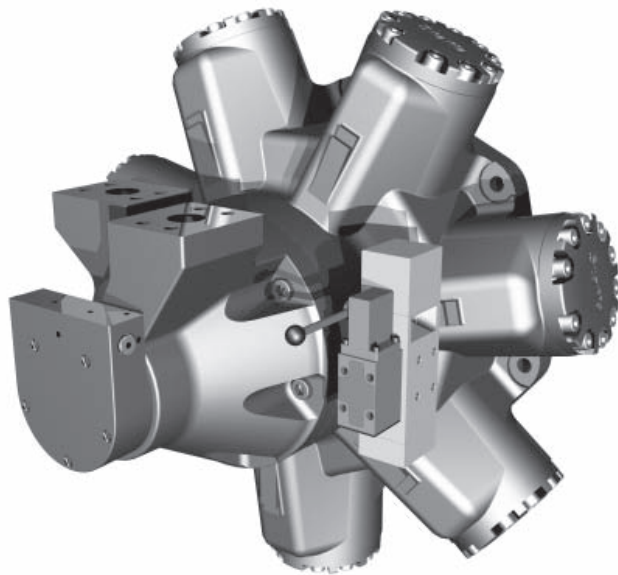

Fig. 5

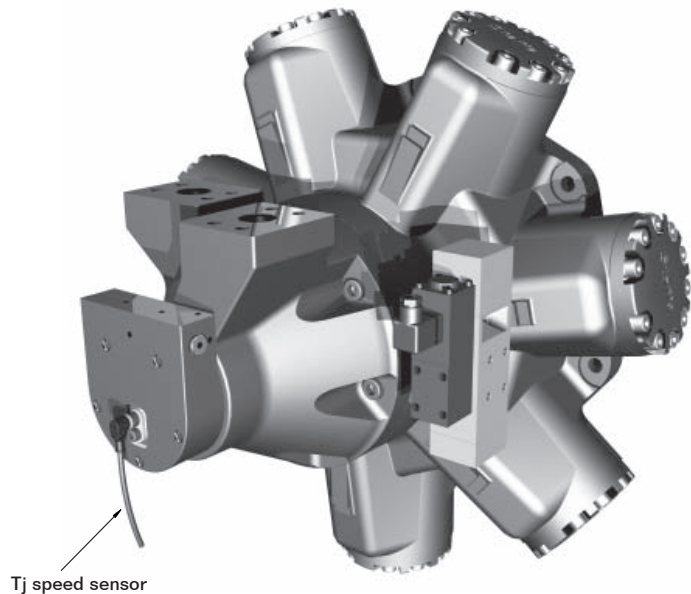

Fig. 6

Motor operation at constant inlet pressure

Fig. 7 shows the relationship between motor displacement and motor inlet pressure. If the inlet pressure is below 7 bar, then the motor will be in its maximum displacement (minimum speed). As the inlet pressure level increases above 7 bar the valve spindle and spool will move directing flow to the large displacement diameter piston (within the shaft assembly), which will force the motor to its minimum displacement (maximum speed).

A further increase in load will increase the motor inlet pressure until the valve pressure setting is reached. At this point, the motor displacement will move away from minimum towards maximum displacement until the motor torque, at valve pressure setting, equals the load torque.

The motor displacement will now automatically adjust itself to maintain the inlet pressure constant at the valve pressure setting. Any further change in load will cause a proportional action from the pressure sensing valve to maintain the motor inlet pressure constant.

HMC270/280/40 MOTOR WITH A VALVE PRESSURE SETTING OF 190 bar

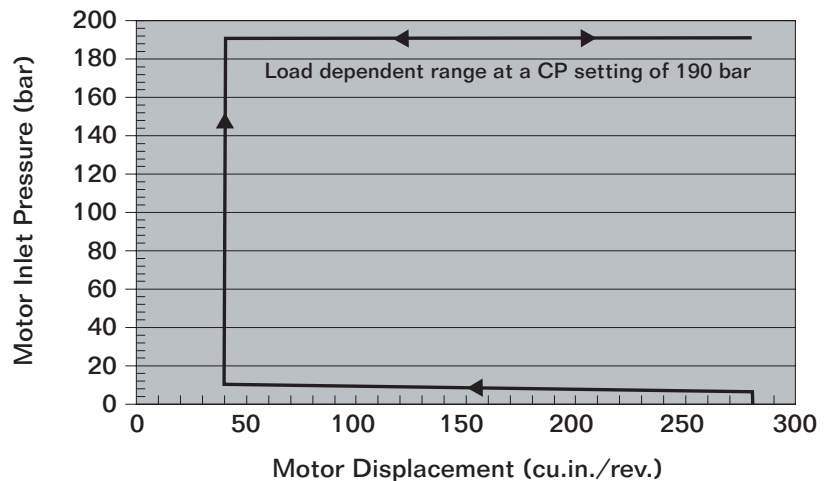
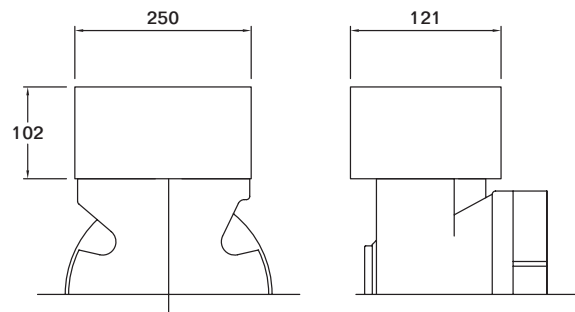
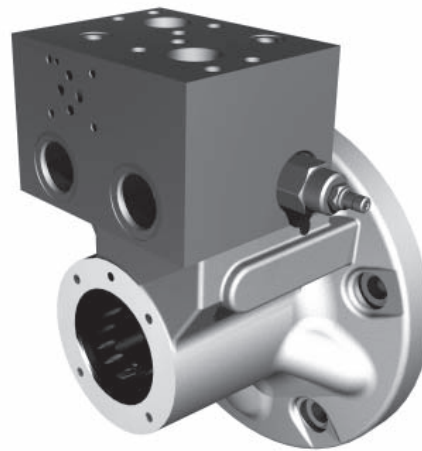
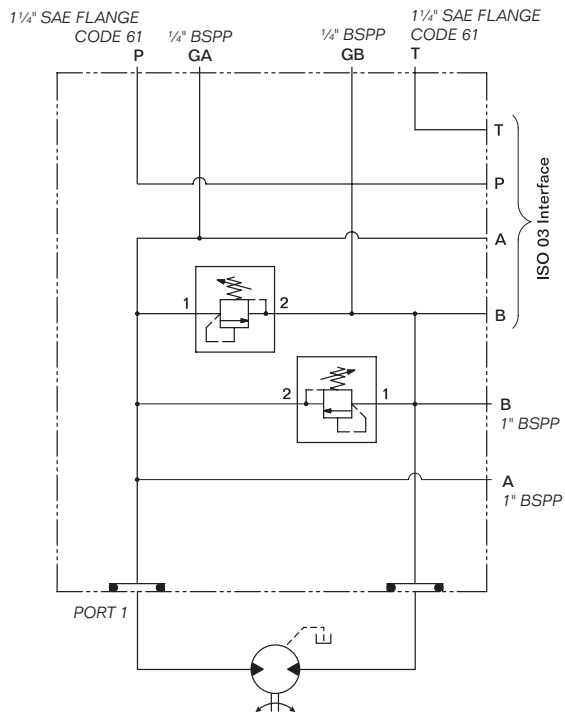

Fig. 7

M0

The valve package is fitted to a FM3 valve housing and includes a CETOP3 interface with two direct acting relief valves of type model RDFA-L**.



M1

The valve package is fitted to a FM3 valve housing and includes two direct acting relief valves of type model RDHA with a rated flow of 380 lpm, and two make-up checks of type model CXFA-XAN.

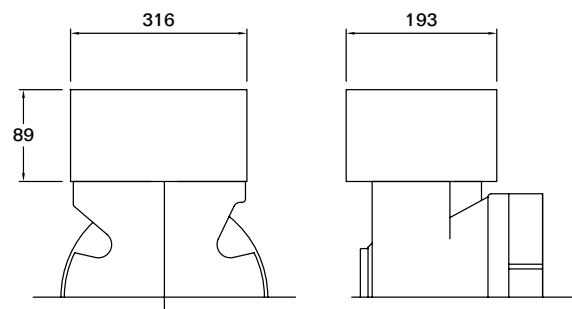
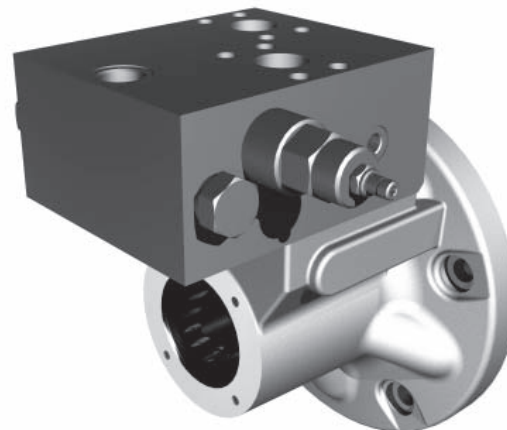
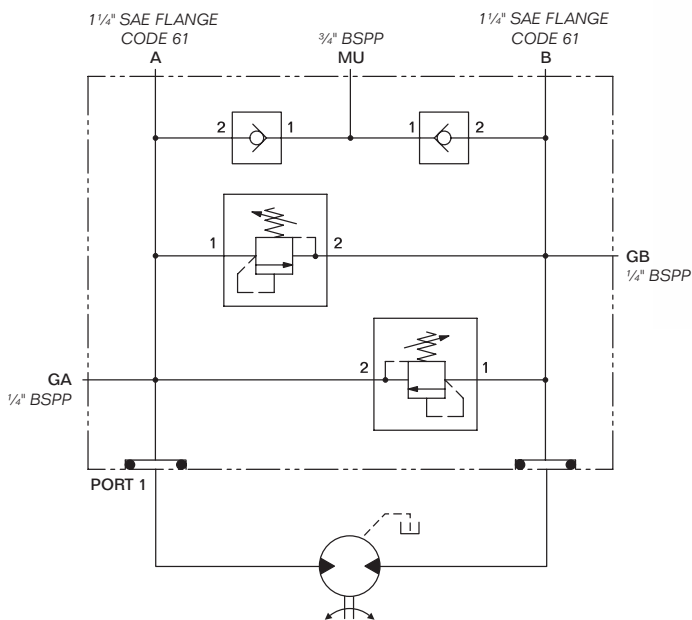

M2

The valve package is fitted to a FM3 valve housing and includes a single counterbalance valve of type model CBIA with a rated flow of 480 lpm, and two make-up checks of type model CXFA-XAN.

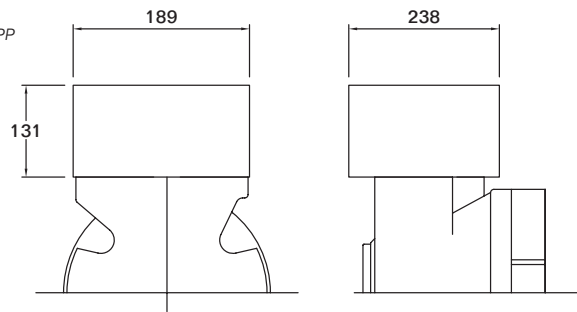
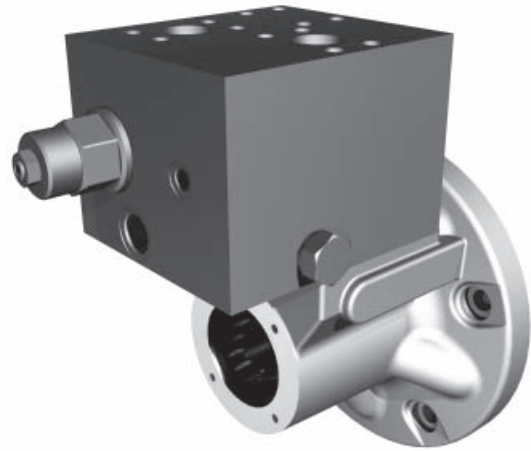
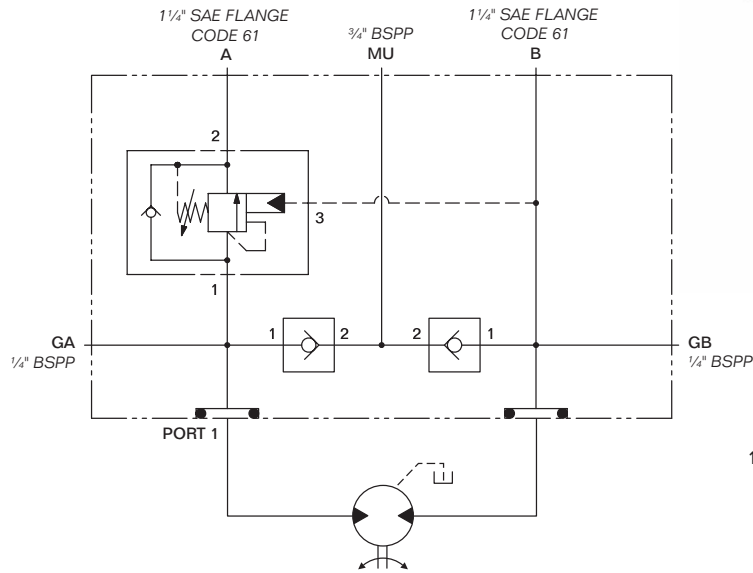

M3

The valve package is fitted to a FM3 valve housing and includes a dual counterbalance valve of type model CBIA with a rated flow of 480 lpm, and two make-up checks of type model CXFA-XAN.

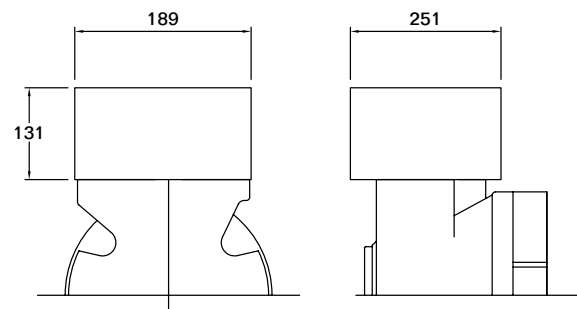
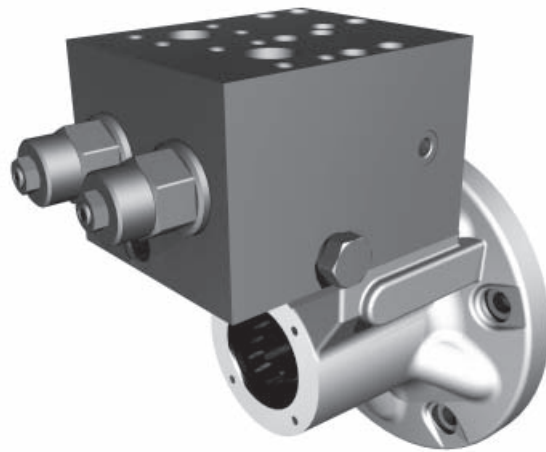
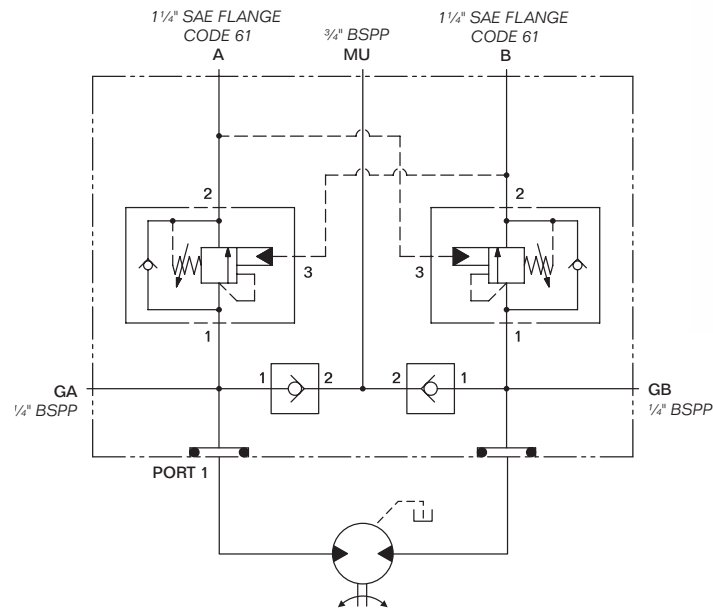

M4

The valve package is fitted to a FM3 valve housing and includes a single pilot operated load control valve of type model MWGM with a rated flow of 480 lpm, pilot relief of type model RBAC and two make-up checks of type model CXFA-XAN.

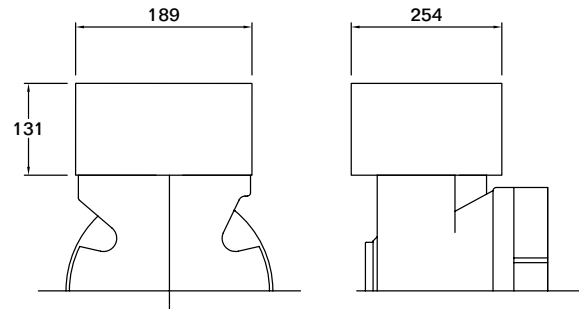
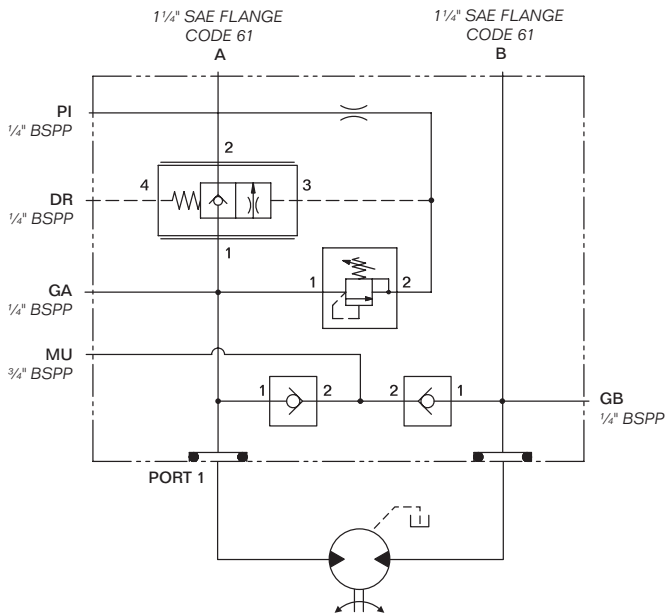
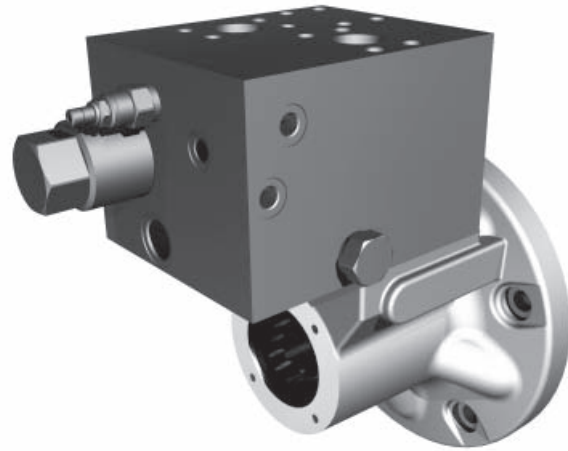

M5

The valve package is fitted to a FM4 valve housing and includes two direct acting relief valves of type model RDJA with a rated flow of 760 lpm, and two make-up checks of type model CXFA-XAN.

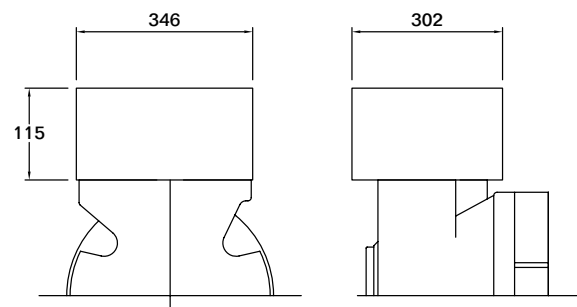
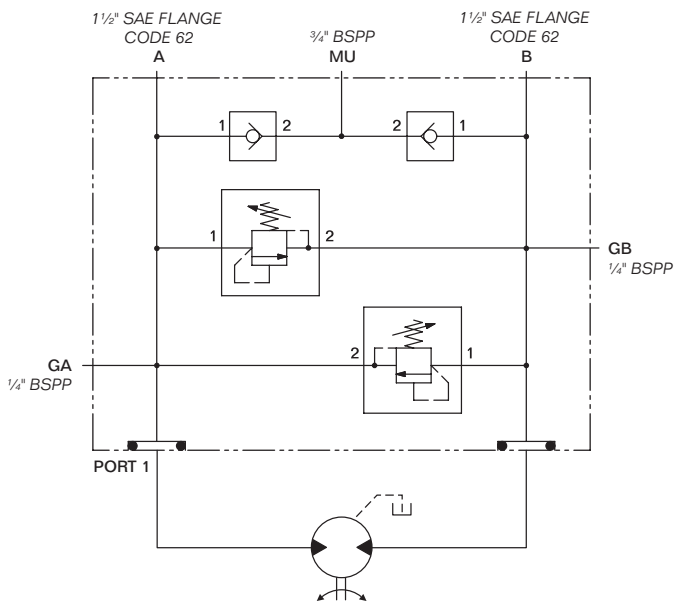
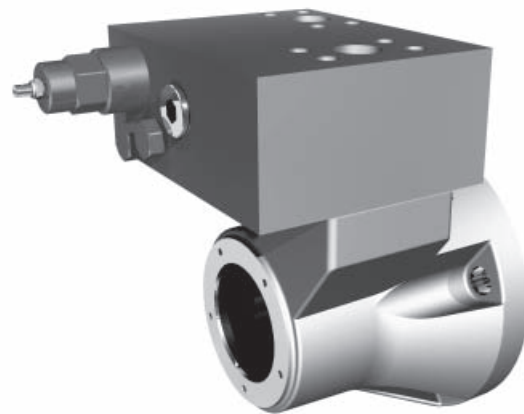

M6

The valve package is fitted to a FM4 valve housing and includes a single counterbalance valve of type model CBIA with a rated flow of 480 lpm, and two make-up checks of type model CXFA-XAN.

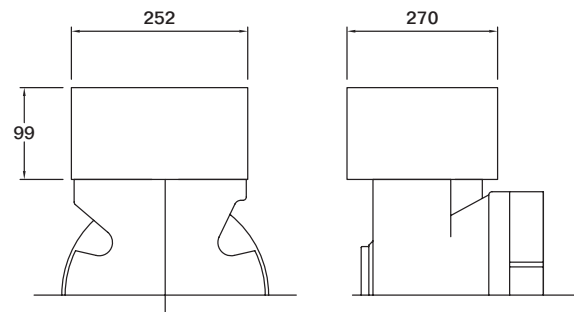
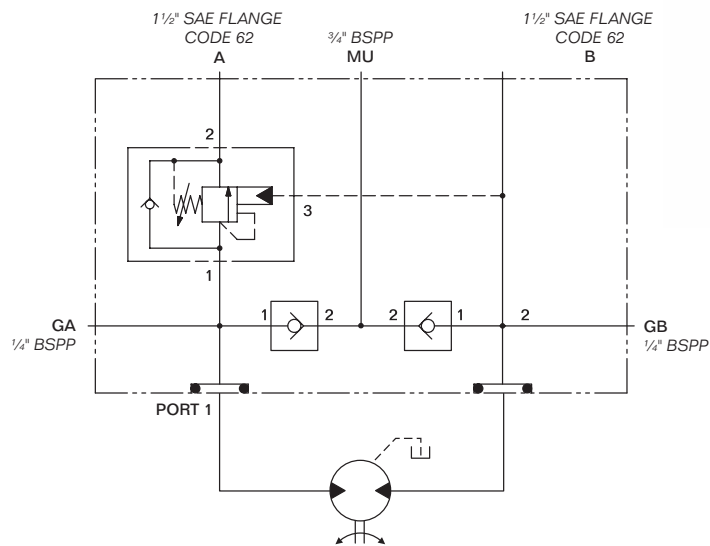

M7

The valve package is fitted to a FM4 valve housing and includes a dual counterbalance valve of type model CBIA with a rated flow of 480 lpm, and two make-up checks of type model CXFA-XAN.

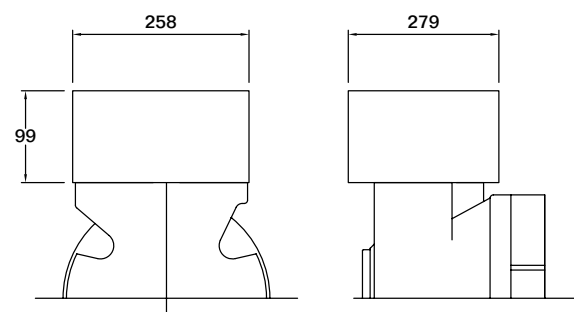
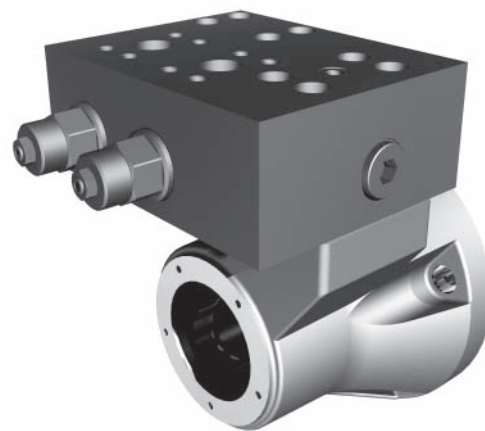
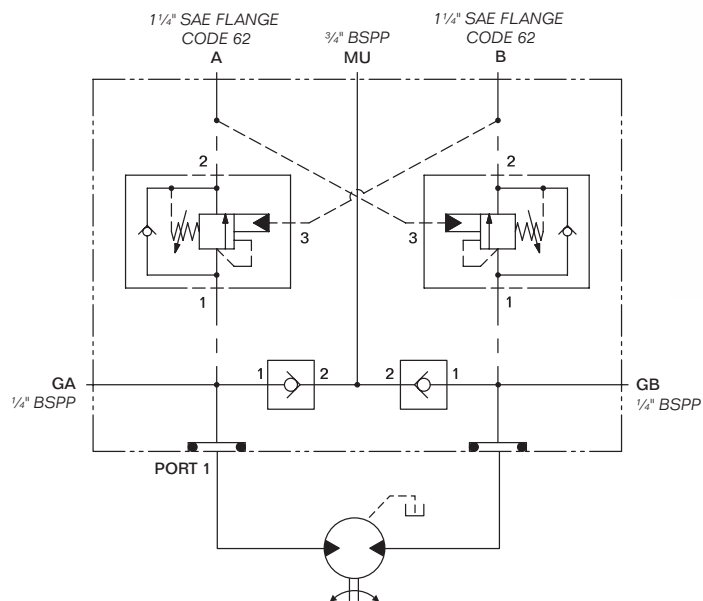

M8

The valve package is fitted to a FM4 valve housing and includes a dual counterbalance valve of type model CBIA with a rated flow of 960 lpm, and two make-up checks of type model CXFA-XAN.

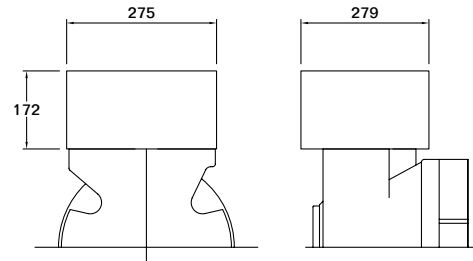
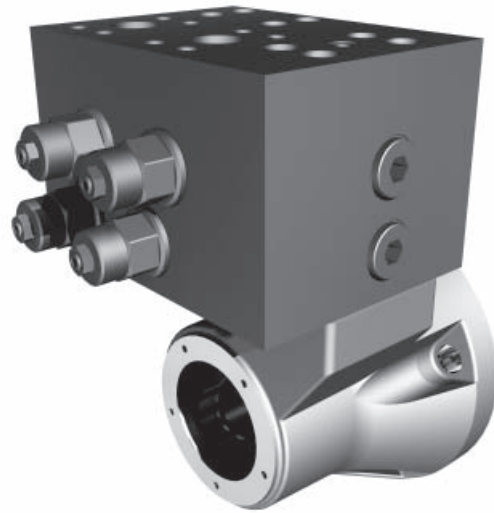
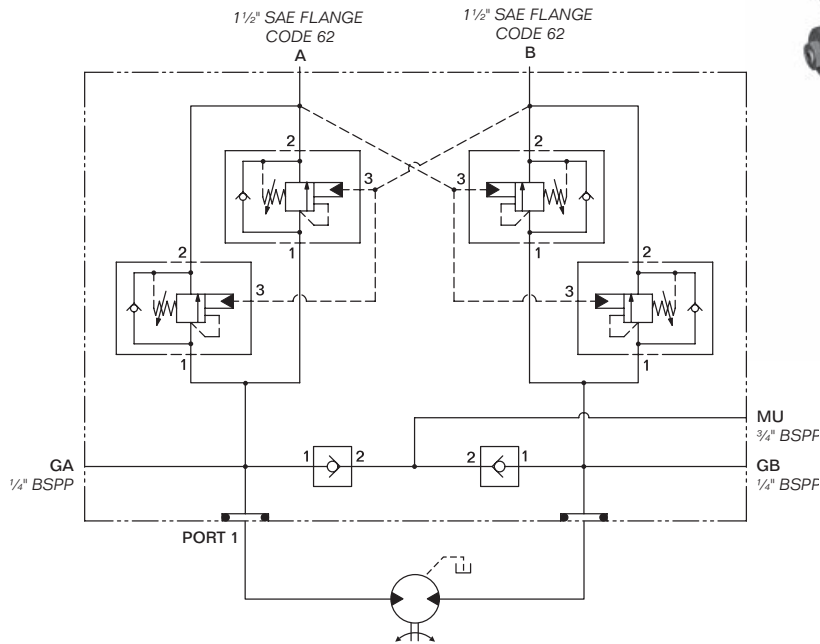

M9

The valve package is fitted to a FM4 valve housing and includes a single pilot operated load control valve of type model MWGM with a rated flow of 480 lpm, pilot relief of type model RBAC and two make-up checks of type model CXFA-XAN.

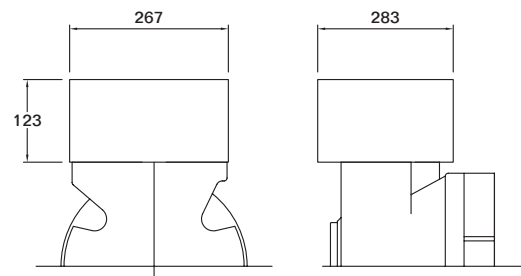
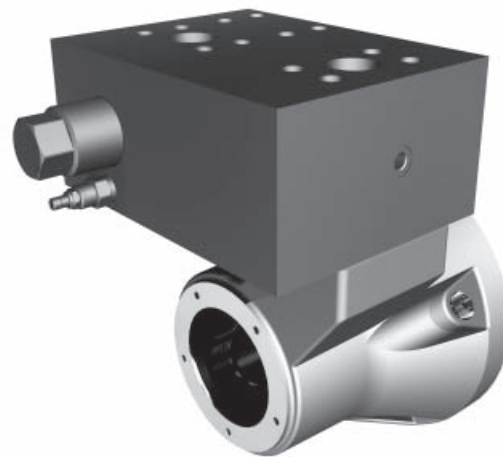
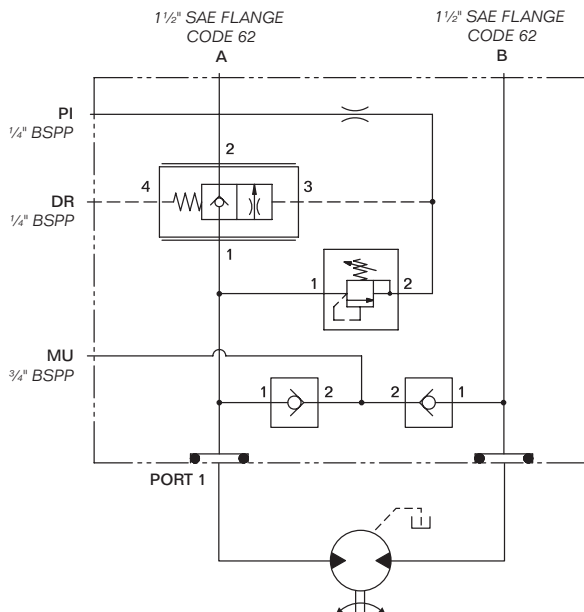

When applying large external radial loads, consideration should also be given to motor bearing lives, (see page 25).

Motor type	Maximum external radial bending moment (kNmm)
HMC030	2600
HMC045	3330
HMC080	4500
HMC125	6500
HMC200	6750
HPHDC200	12200
HMC270	8250
HPHDC270	16000
HMC325	8250

Example:

Determine the maximum radial shaft load of a HMC080 motor:

Radial load offset, A = 100mm
 Maximum radial load, W = 4500 (see table)/100
 = **45kN (4587 kg)**

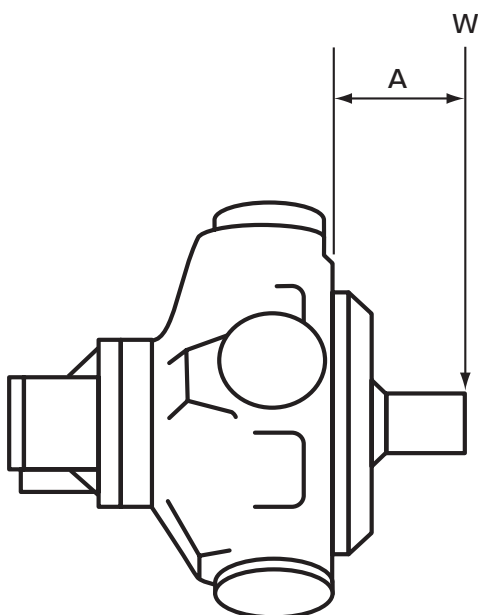

A = Distance from mounting face to load centre
 W = Side load

NOTE: The offset distance A is assumed to be greater than 50mm. Contact KPM UK LTD if this is not the case.

Consideration should be given to the required motor bearing life in terms of bearing service life. The factors that will determine bear life include:

1. Duty cycle - time spent on and off load
2. Speed
3. Differential pressure
4. Fluid viscosity, type, cleanliness and temperature
5. External radial shaft load
6. External axial shaft load

A heavy duty HM(HD)C motor can be ordered to further improve bearing life. Consult KPM if you need a detailed bearing life calculation.

Limits for fire resistant fluids

To select either displacement, a pressure at least equal to 2/3 of the motor inlet/outlet pressure (*whichever is higher*) is required. In most applications the motor inlet pressure will be used. If the inlet/outlet pressure is below 3.5 bar, a minimum control pressure of 3.5 bar is required. In the event of loss of control pressure the motor will shift to its highest displacement.

Starting torque

Refer to performance data, (see pages 4 to 10).

Low speed operation

The minimum operating speed is determined by load inertia, drive elasticity, motor displacement and system internal leakage. If the application speed is below 3 rpm, then consult KPM.

If possible, always start the motor in high displacement.

Small displacements

The pressures given in the table on pages 4 to 10 for displacement code "00" are based on 1000 rpm output shaft speed. This pressure can be increased for shaft speeds less than 1000 rpm; consult Kawasaki for details. Speeds greater than 1000 rpm may be applied but only after the machine duty cycle has been considered in conjunction with KPM.

A zero swept volume displacement (*for freewheeling requirements*) is available on request, consult KPM.

High back pressure

When both inlet and outlet ports are pressurised continuously, the lower pressure port must not exceed **70 bar** at any time. Note that high back pressure reduces the effective torque output of the motor.

Boost pressure

When operating as a motor the outlet pressure should equal or exceed the crankcase pressure. If pumping occurs (*i.e. overrunning loads*) then a positive pressure, "P", is required at the motor ports. Calculate "P" (bar) from the boost formula:

$$P = 1 + \frac{N^2 \times V^2}{K} + C$$

Where P is in bar, N = motor speed (rpm), V = motor displacement (cc/rev.), C=Crankcase pressure (bar).

Motor	Porting	Constant (K)
HMC030	F2, FM2	3.7 x 10 ⁹
	S03, F3, FM3	7.5 x 10 ⁹
HMC045	F2, FM2	3.7 x 10 ⁹
	S03, F3, FM3	1.6 x 10 ¹⁰
HMC080	S03, F3, FM3	1.6 x 10 ¹⁰
HMC125	S03, F3, FM3	1.6 x 10 ¹⁰
HMC200	S03, F3, FM3	1.6 x 10 ¹⁰
	S04, F4, FM4	3.3 x 10 ¹⁰
HMC270	S04, F4, FM4	4 x 10 ¹⁰
HMC325	S04, F4, FM4	4 x 10 ¹⁰

The flow rate of oil for the make-up system can be estimated from the crankcase leakage data (see page 11) plus an allowance for changing displacement:

e.g.

HMC030	To change high to low in 0.2 seconds requires 11 lpm
HMC045	To change high to low in 0.25 seconds requires 15 lpm
HMC080	To change high to low in 0.25 seconds requires 32 lpm
HMC125	To change high to low in 0.5 sec requires 15 lpm
HMC200	To change high to low in 0.5 sec requires 15 lpm
HMC270	To change high to low in 1 sec requires 24 lpm
HMC325	To change high to low in 1 sec requires 20 lpm

Allowances should be made for other systems losses and also for "fair wear and tear" during the life of the motor, pump and system components.

Motorcase pressure

The motorcase pressure should not continuously exceed 3.5 bar with a standard shaft seal fitted. On installations with long drain lines a relief valve is recommended to prevent over-pressurising the seal.

Notes:

1. The motorcase pressure at all times must not exceed either the motor inlet or outlet pressure.
2. High pressure shaft seals are available to special order for casing pressures of: 10 bar continuous and 15 bar intermittent.
3. Check installation dimensions (pages 39 to 52) for maximum crankcase drain fitting depth.

Hydraulic fluids

Dependent on motor (see model code fluid type - page 57) suitable fluids include:

- (a) Antiwear hydraulic oils
- (b) Phosphate ester (HFD fluids)
- (c) Water glycols (HFC fluids)
- (d) 60/40% water-in-oil emulsions (HFB fluids)
- (e) 5/95% oil-in-water emulsions (HFA fluids)

Reduce pressure and speed limits, as per table on page 3.

Viscosity limits when using any fluid except oil-in-water (5/95) emulsions are:

Max. off load:	2000 cSt (9270 SUS)
Max. on load:	150 cSt (695 SUS)
Optimum:	50 cSt (232 SUS)
Minimum:	25 cSt (119 SUS)

Mineral oil recommendations

The fluid should be a good hydraulic grade, non-detergent petroleum oil. It should contain anti-oxidant, antifoam and demulsifying additives. It must contain antiwear or EP additives. Automatic transmission fluids and motor oils are not recommended.

Temperature limits

Ambient min.	-30°C	
Ambient max.	+70°C	
Max. operating temperature range.		
	Petroleum oil	Water- containing
Min	-20°C	+10°C
Max. *	+80°C	+54°C

* To obtain optimum services life from both fluid and hydraulic systems components, 65°C normally is the maximum temperature expected for water-containing fluids.

Filtration

Full flow filtration (*open circuit*), or full boost flow filtration (*close circuit*) to ensure system cleanliness to ISO4406/1986 code 18/14 or cleaner. Note: If a CP valve is used, then 17/13 or cleaner is recommended.

Noise levels

The airborne noise level is less than 66.7 dBA (DIN) through the “continuous” operating envelope. Where noise is a critical factor, installation resonances can be reduced by isolating the motor by elastomeric means from the structure and the return line installation. Potential return line resonance originating from liquid borne noise can be further attenuated by providing a return line back pressure of 2 to 5 bar.

Polar moment of Inertia

Typical data:

Motor	Displacement code	Kgm ²
HMC030	30	0.012
	15	0.0094
HMC045	45	0.044
	30	0.041
HMC080	90	0.052
	45	0.044
HMC125	125	0.20
	50	0.14
HMC200	188	0.23
	75	0.18
HMC270	280	0.83
	100	0.61
HMC325	325	0.87
	100	0.61

Mass

HMC030 Approx. all models 100kg.
 HMC045 Approx. all models 150kg.
 HMC080 Approx. all models 172kg.
 HMC125 Approx. all models 235kg.
 HMC200 Approx. all models 282kg.
 HMC270 Approx. all models 450kg.
 HMC325 Approx. all models 460kg.

When operating the motor at low temperature consideration should be given to the fluid viscosity. The maximum fluid viscosity before the shaft should be turned is 2000 cSt. The maximum fluid viscosity before load is applied to the motor shaft is 150 cSt.

If low ambient temperature conditions exist, then a crankcase flushing flow of 5 lpm should be applied to the motor during periods when the motor is not in use.

The shaft seal temperature limits for both medium and high pressure applications are shown in the table below.

	Non-operating temperature limits	Minimum operating temperature
Medium pressure shaft seal	below minus 40 and above 100 degrees C	minus 30 degrees C
High pressure shaft seal	below minus 30 and above 120 degrees C	minus 15 degrees C

All seals are very brittle at minus 40° C and are likely to break very easily and due to their sluggish response may not provide a 100% leak free condition.

It should be noted that the maximum continuous operating temperature within the motor crankcase is plus 80° C.

It is recommended that the motor is operated by observing the rule for viscosity and the minimum operating temperature.

All Staffa motors can be used in freewheeling applications. In all circumstances it is essential that the motor is unloaded (*A and B ports connected together*) and that the circuit is boosted.

The required boost pressure will be dependent on speed and displacement.

It should be noted that for 'B' series motors large flows will re-circulate around the motor. This will require a large re-circulating valve and consideration of circuit cooling as the motor will generate a braking torque. It is for these reasons that 'C' series motors are the preferred option for freewheeling applications. It is normal to select displacement codes 10, 05 or 00.

Selecting the lowest available displacement of zero (00) will allow the motor shaft to be rotated at high speed without pumping fluid and with a minimum boost requirement. This will result in a minimum drive torque requirement for the freewheeling motor. Examples of the freewheeling feature on a winch are : dropping the load quickly in the case of an emergency and paying out cable. Consideration should be given when freewheeling such that the load does not drive the motor above its rated freewheeling speed.

Displacement selection

If the motor inlet/outlet pressure is below 3.5 bar, then a minimum 3.5 bar control pressure is required in order to ensure that the motor remains in minimum displacement. It should be noted that in the event of loss of control pressure, the motor will shift to its highest displacement, which could result in damage to the motor. When freewheeling with displacement codes: 00, 05 or 10, it can be difficult to generate a 3.5 bar pressure. In these circumstances it is necessary to feed the displacement change control circuit from a separate source thus ensuring a minimum control pressure of 3.5 bar. Under all operating conditions the control pressure port should be at least 2/3 of the motor inlet/outlet pressure ports.

Boost requirement

The required boost pressure is detailed on page 26. The actual required level will be determined by the expected maximum speed in maximum displacement during the overrunning condition. A maximum motor and control pressure of 17 bar at 1000 rpm is stated in the bulletins, although for purposes of freewheeling it is better to maintain a minimum boost level that satisfies all motor operating conditions. The Staffa motor bulletin boost formula does not apply to freewheeling displacements. High boost levels will increase motor losses at the conrod slipper interface and valve assembly, which will increase the motor operating temperature.

The boost flow required should be sufficient to make-up circuit leakage loss and provide cooling for recirculating flow pressure drop.

Crankcase cooling

A crankcase flushing flow of up to 15 lpm can be used to control and reduce the temperature rise of the motor during the freewheeling operation. This should not be necessary for motor speeds upto 1000 rpm but for freewheel speeds upto 1500 rpm then crankcase flushing flow must be used.

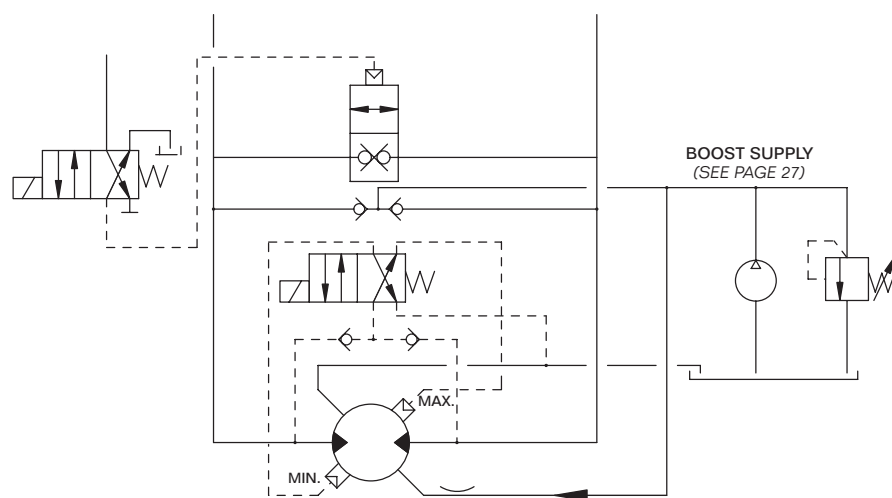

TYPICAL FREEWHEEL CIRCUIT
(EXAMPLE MODEL CODE - HMC200/S/188/00/FM3/CS/70)

General

Spigot

The motor should be located by the mounting spigot on a flat, robust surface using correctly sized bolts. The diametrical clearance between the motor spigot and the mounting must not exceed 0.15mm. If the application incurs shock loading, frequent reversing or high speed running, then high tensile bolts should be used, including one fitted bolt.

Bolt torque

The recommended torque wrench setting for bolts is as follows:

M18	312 +/- 7 Nm
5/8" UNF	265 +/- 14 Nm
M20	407 +/- 14 Nm
3/4" UNF	393 +/- 14 Nm

Shaft coupling

Where the motor is solidly coupled to a shaft having independent bearings the shaft must be aligned to within 0.13mm TIR.

Motor axis - horizontal

The crankcase drain must be taken from a position above the horizontal centre line of the motor, (see page 32).

Motor axis - vertical shaft up

The recommended minimum pipe size for drain line lengths up to approx. 5m is 12.0mm as an internal diameter. If using longer drain lines, then increase the pipe internal bore diameter to keep the motorcase pressure within specified limits.

Specify "V" in the model code for extra drain port, G^{1/4}" (BSPF). Connect this port into main drain line downstream of a 0.35 bar check valve.

Motor axis - vertical shaft down

Piping (from any drain port) must be taken above level of motorcase.

Bearing lubrication - piping

The installation arrangement must not allow syphoning from the motorcase. Where this arrangement is not practical, please consult KPM.

Any of the drain port positions can be used, but the drain line should be run above the level of the uppermost bearing and if there is risk of syphoning then a syphon breaker should be fitted.

Start - up

Fill the crankcase with system fluid. Where practical, a short period (30 minutes) of "running in" should be carried out with the motor set to its high displacement.

Motor axis - horizontal

The recommended minimum pipe size for drain line lengths up to approx. 5m is 12.0mm 1/2" bore. Longer drain lines should have their bore size increased to keep the crankcase pressure within limits.

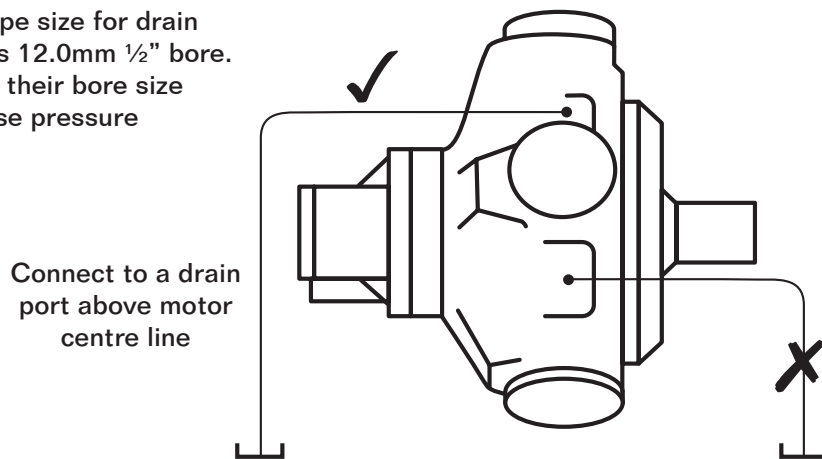

Motor axis - vertical shaft up

Specify "V" within the model code for extra drain port, G1/4" (BSPF). Connect this port into the main drain line downstream of a 0.35 bar check valve to ensure good bearing lubrication. The piping arrangement must not allow syphoning from the motorcase.

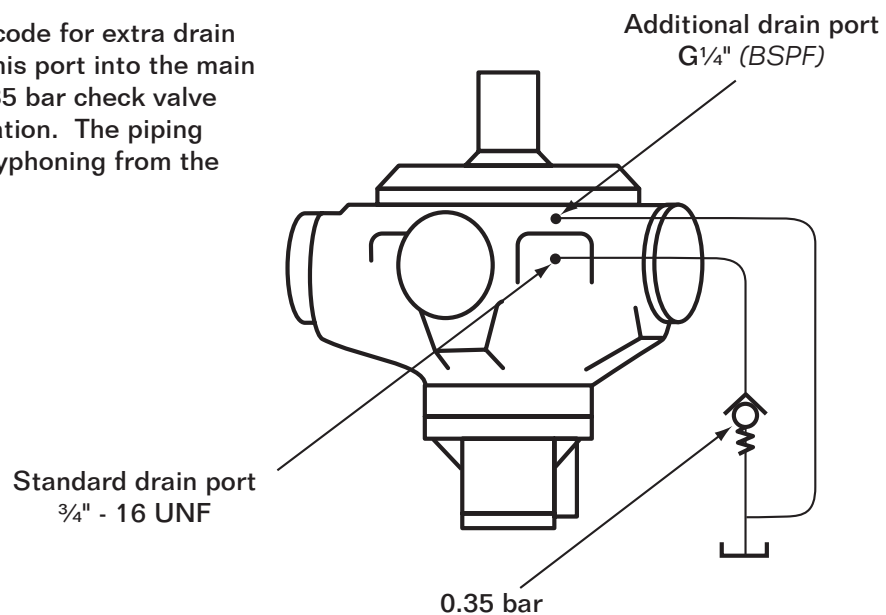

Motor axis - vertical shaft down

The piping, from any drain port, must be taken above the level of the motorcase to ensure good bearing lubrication. The arrangement must not allow syphoning from the motorcase.

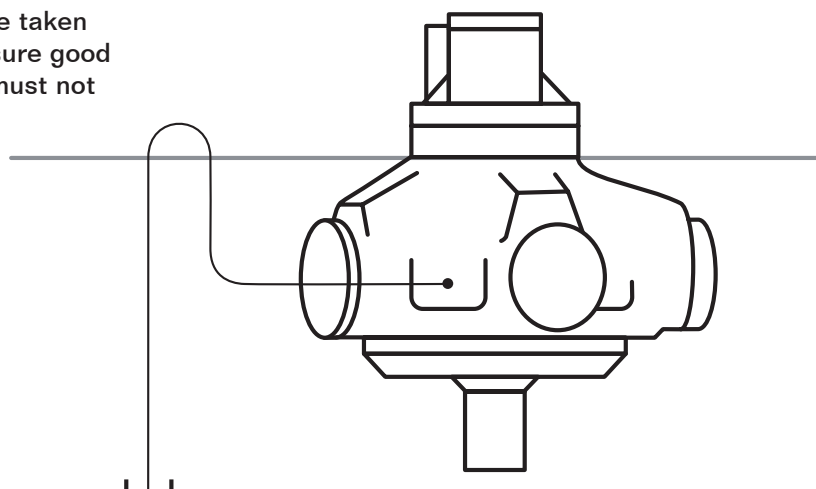

HMC030 - Example model code - HMC030/P/30/15/FM3/X/70

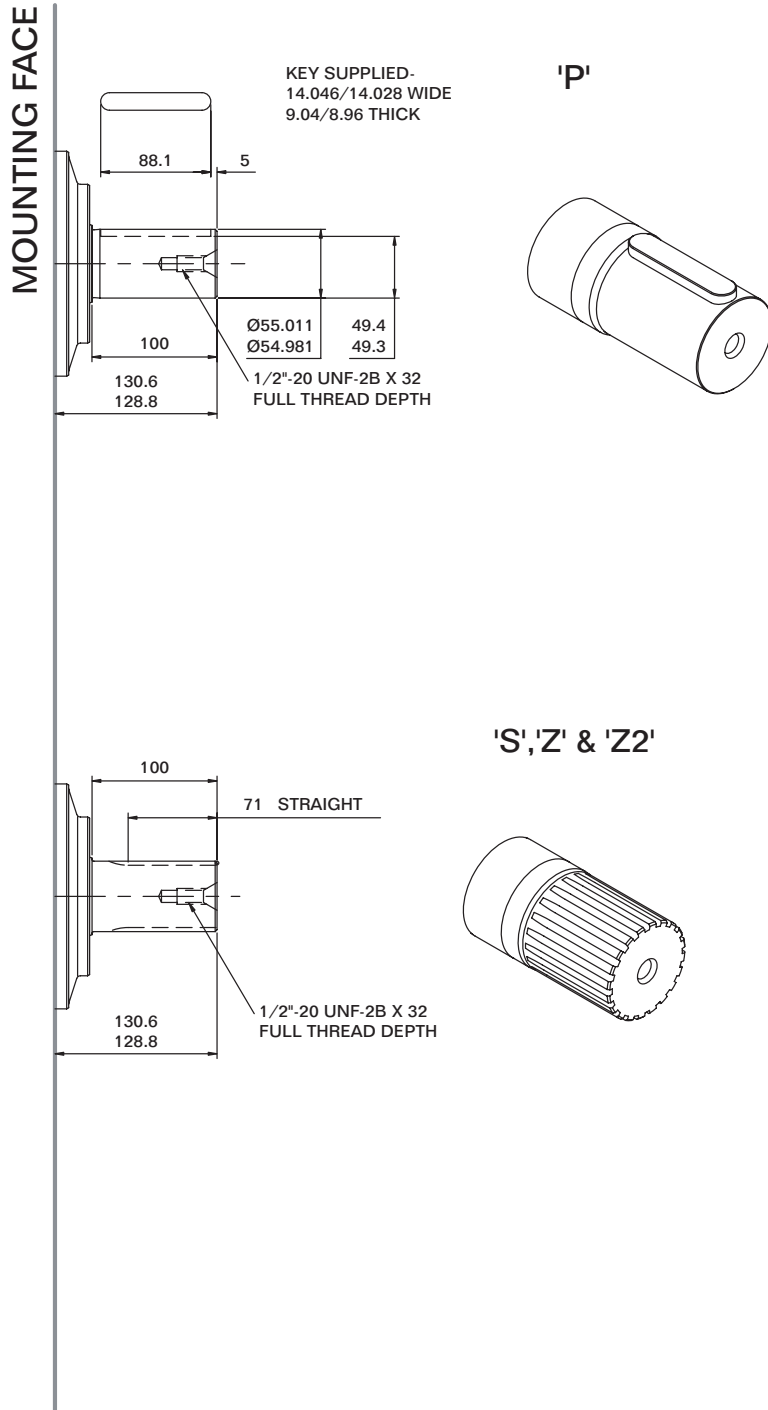

SPLINE DATA

'S'	
TO BS 3550 (ANSI B92.1 CLASS 5)	
FLAT ROOT SIDE FIT, CLASS 1	
PRESSURE ANGLE	30°
NUMBER OF TEETH	17
PITCH	8/16
MAJOR DIAMETER	56.41/56.29
FORM DIAMETER	50.70
MINOR DIAMETER	50.06/49.60
PIN DIAMETER	6.096
DIAMETER OVER PINS	62.984/62.931

'Z'	
DIN 5480 W55 x 3 x 17 x 7h	

'Z2'	
DIN 5480 W60 x 3 x 18 x 7h	

HMC045 - Example model code - HMC045/P/45/20/FM3/X/70

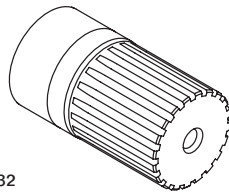
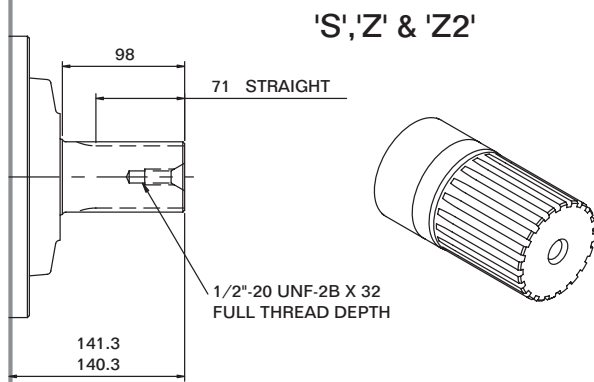
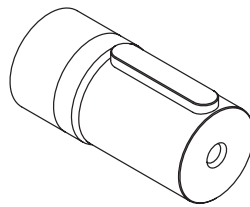
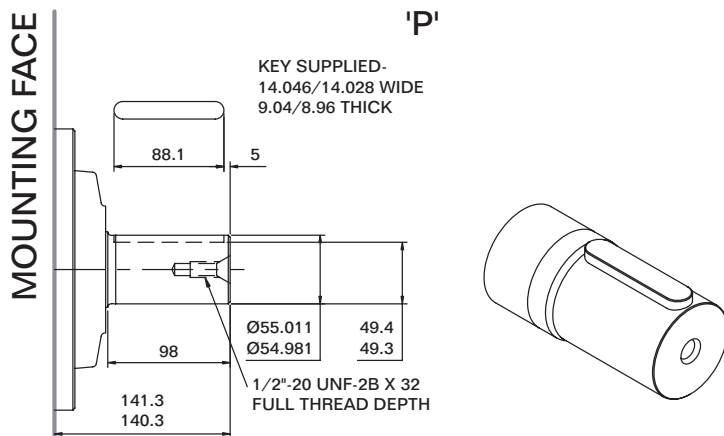

SPLINE DATA

'S'	
TO BS 3550 (ANSI B92.1 CLASS 5)	
FLAT ROOT SIDE FIT, CLASS 1	
PRESSURE ANGLE	30°
NUMBER OF TEETH	17
PITCH	8/16
MAJOR DIAMETER	56.41/56.29
FORM DIAMETER	50.70
MINOR DIAMETER	50.06/49.60
PIN DIAMETER	6.096
DIAMETER OVER PINS	62.984/62.931

'Z'
DIN 5480 W55 x 3 x 17 x 7h

'Z2'
DIN 5480 W60 x 3 x 18 x 7h

HMC080 - Example model code - HMC080/P/90/20/FM3/X/70

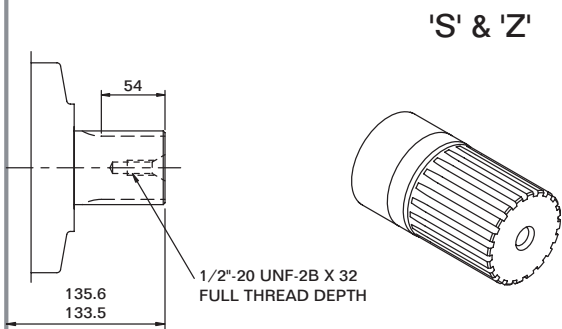
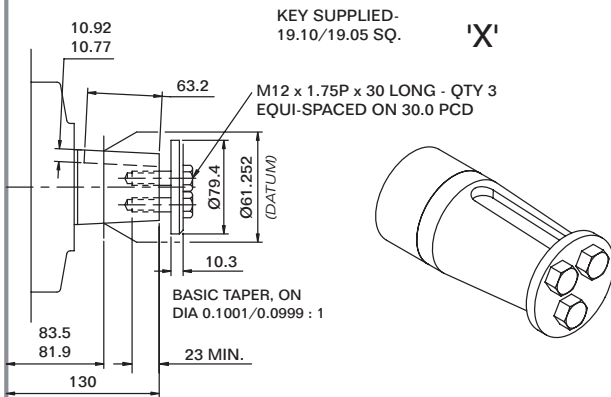
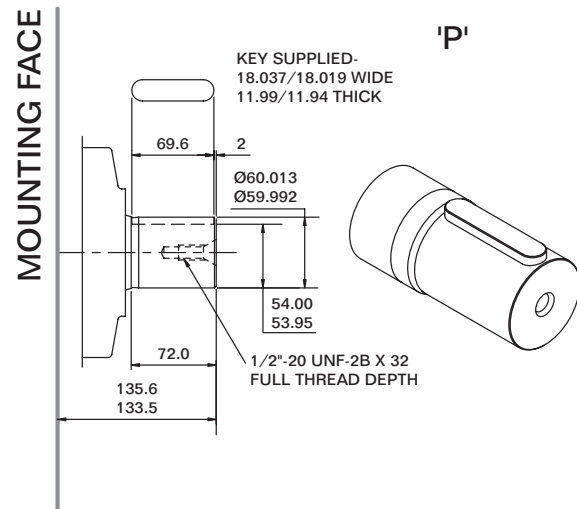
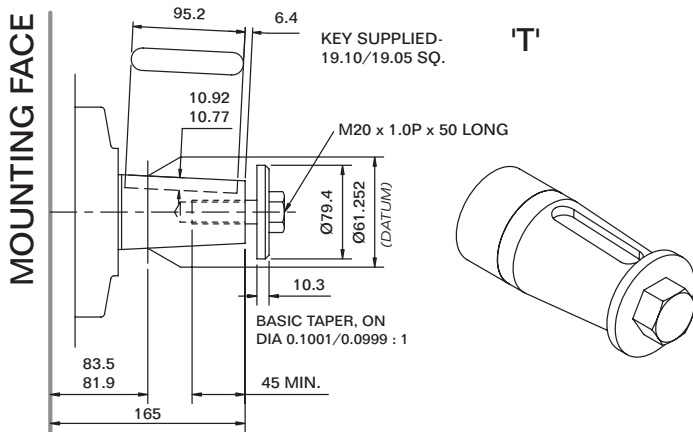

SPLINE DATA

'S'	
TO BS 3550 (ANSI B92.1 CLASS 5)	
FLAT ROOT SIDE FIT, CLASS 1	
PRESSURE ANGLE	30°
NUMBER OF TEETH	14
PITCH	6/12
MAJOR DIAMETER	62.553/62.425
FORM DIAMETER	55.052
MINOR DIAMETER	54.084/53.525
PIN DIAMETER	8.128
DIAMETER OVER PINS	71.593/71.544

'Z'
DIN 5480 W70 x 3 x 30 x 22 x 7h

HMC125 - Example model code - HMC125/P/125/100/FM3/X/70

MOUNTING FACE

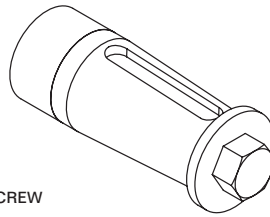
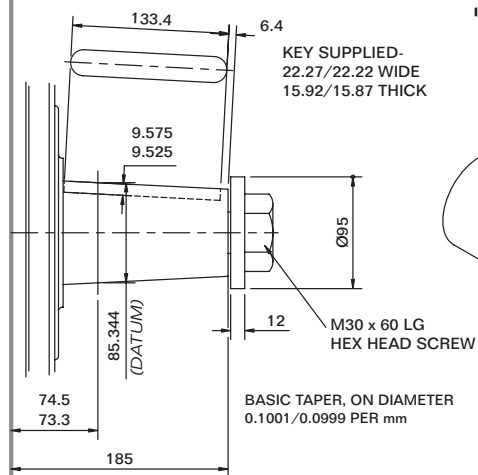

MOUNTING FACE

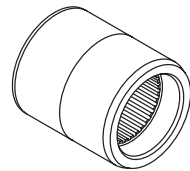
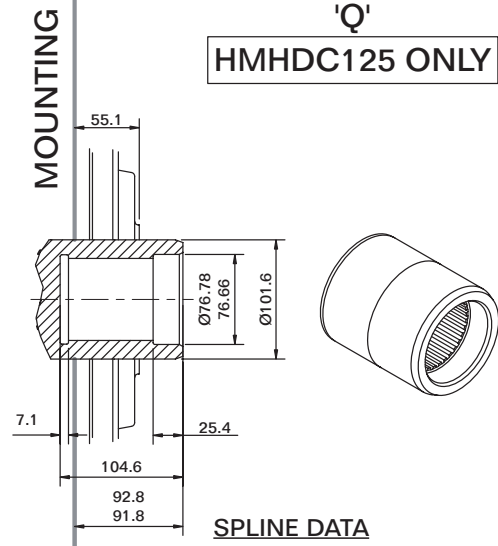

'P1'

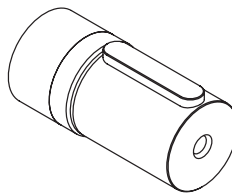
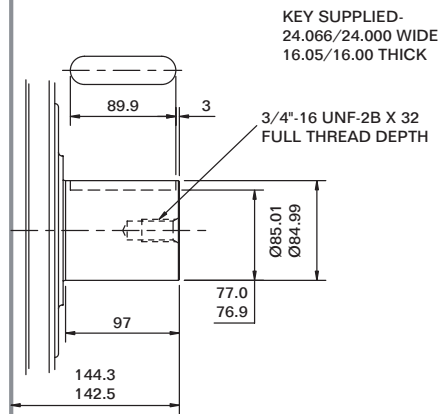

'S3' & 'Z3'

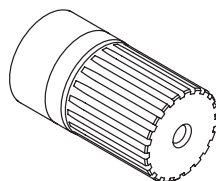
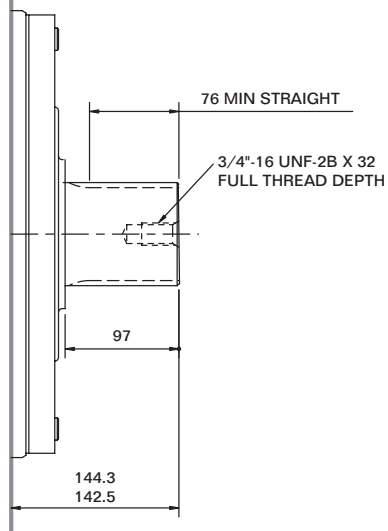

SPLINE DATA

'S3'	
TO BS 3550/SAE J498c (ANSI B92.1, CLASS 5)	
FLAT ROOT SIDE FIT, CLASS 1	
PRESSURE ANGLE	30°
NUMBER OF TEETH	20
PITCH	6/12
MAJOR DIAMETER	87.953/87.825
FORM DIAMETER	80.264
MINOR DIAMETER	79.485/78.925
PIN DIAMETER	8.128
DIAMETER OVER PINS	97.084/97.030

'Z3'	
DIN 5480 W85 x 3 x 27 x 7h	

HMC200 - Example model code - HMC200/P/180/60/FM3/X/70

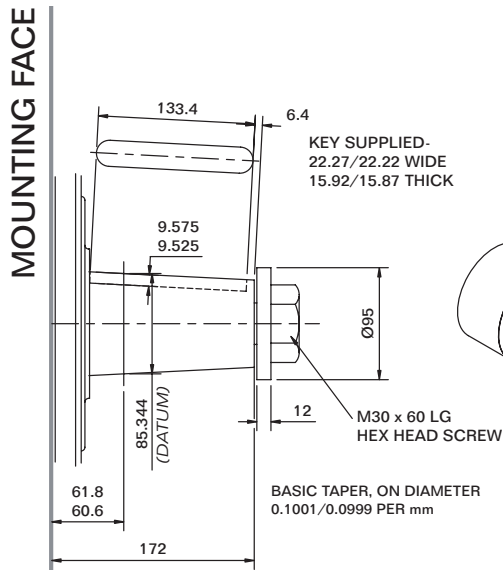

'T'

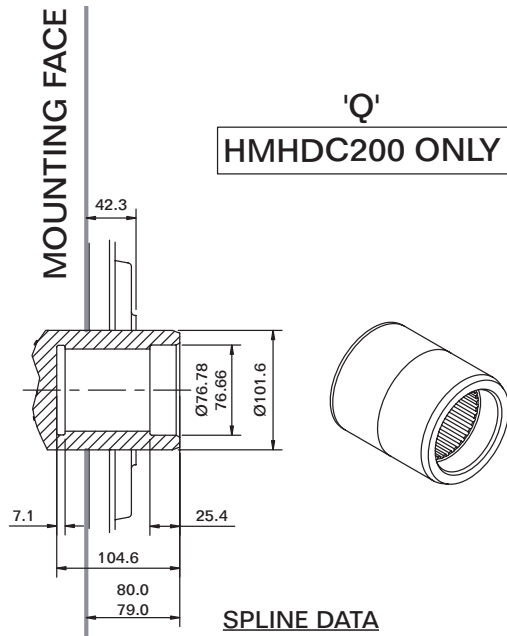
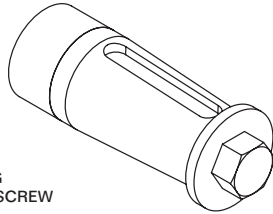

'Q'

HMHDC200 ONLY

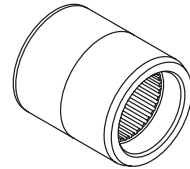

SPLINE DATA

SPLINE TO BS 3550	
FLAT ROOT SIDE FIT	
CLASS 1	
NUMBER OF TEETH	34
PITCH	12/24
PRESSURE ANGLE	30°

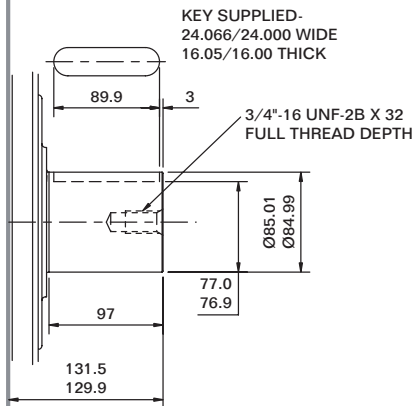

'P1'

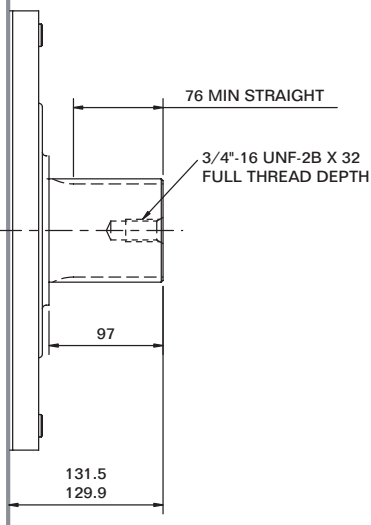
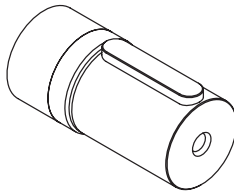

'S3' & 'Z3'

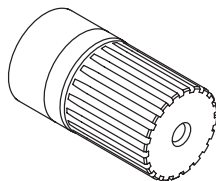

SPLINE DATA

'S3'

TO BS 3550/SAE J498c (ANSI B92.1, CLASS 5)	
FLAT ROOT SIDE FIT, CLASS 1	
PRESSURE ANGLE	30°
NUMBER OF TEETH	20
PITCH	6/12
MAJOR DIAMETER	87.953/87.825
FORM DIAMETER	80.264
MINOR DIAMETER	79.485/78.925
PIN DIAMETER	8.128
DIAMETER OVER PINS	97.084/97.030

'Z3'

DIN 5480 W85 x 3 x 27 x 7h

HMC270/HMC325 - Example model code - HMC270/S/280/60/FM4/X/70

- Example model code - HMC325/S/300/60/FM4/X/70

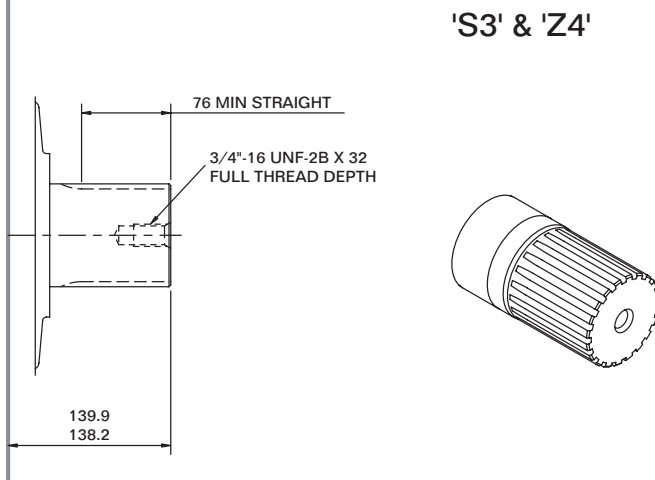
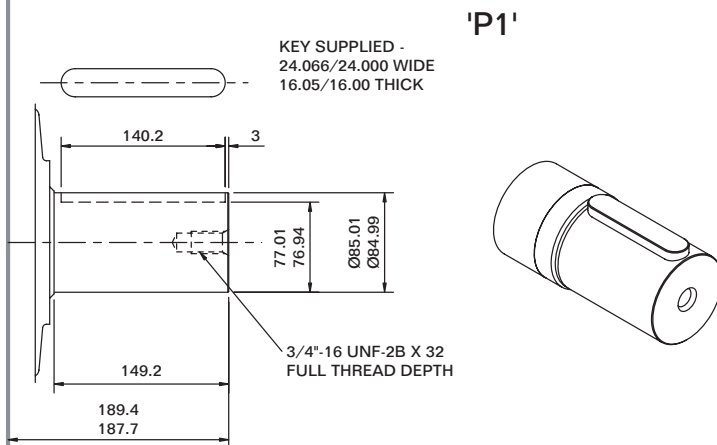
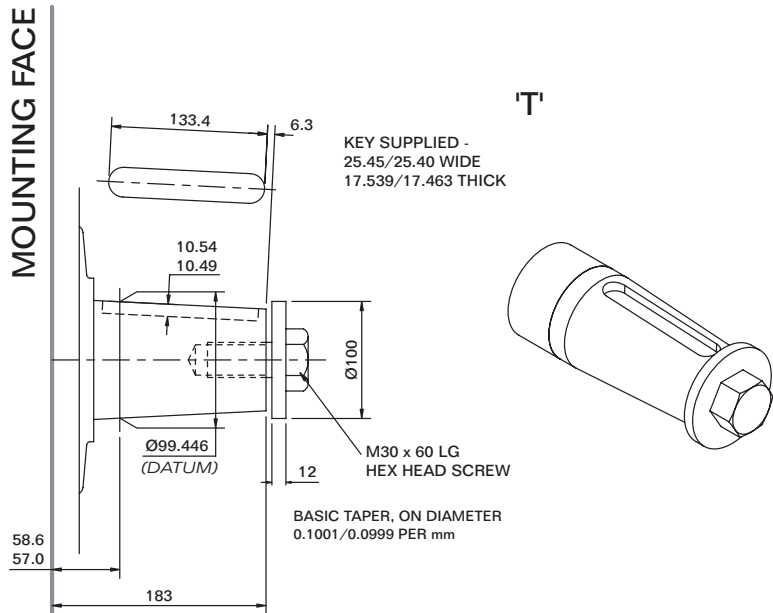

SPLINE DATA

'S3'	
TO BS 3550 (ANSI B92.1, CLASS 5)	
FLAT ROOT SIDE FIT, CLASS 1	
PRESSURE ANGLE	30°
NUMBER OF TEETH	20
PITCH	6/12
MAJOR DIAMETER	87.953/87.825
FORM DIAMETER	80.264
MINOR DIAMETER	79.485/78.925
PIN DIAMETER	8.128
DIAMETER OVER PINS	97.084/97.030

'Z4'	
DIN 5480 W90 x 4 x 21 x 7h	

HMC030 installation

Example model code - HMC030/S/30/20/FM3/X/70

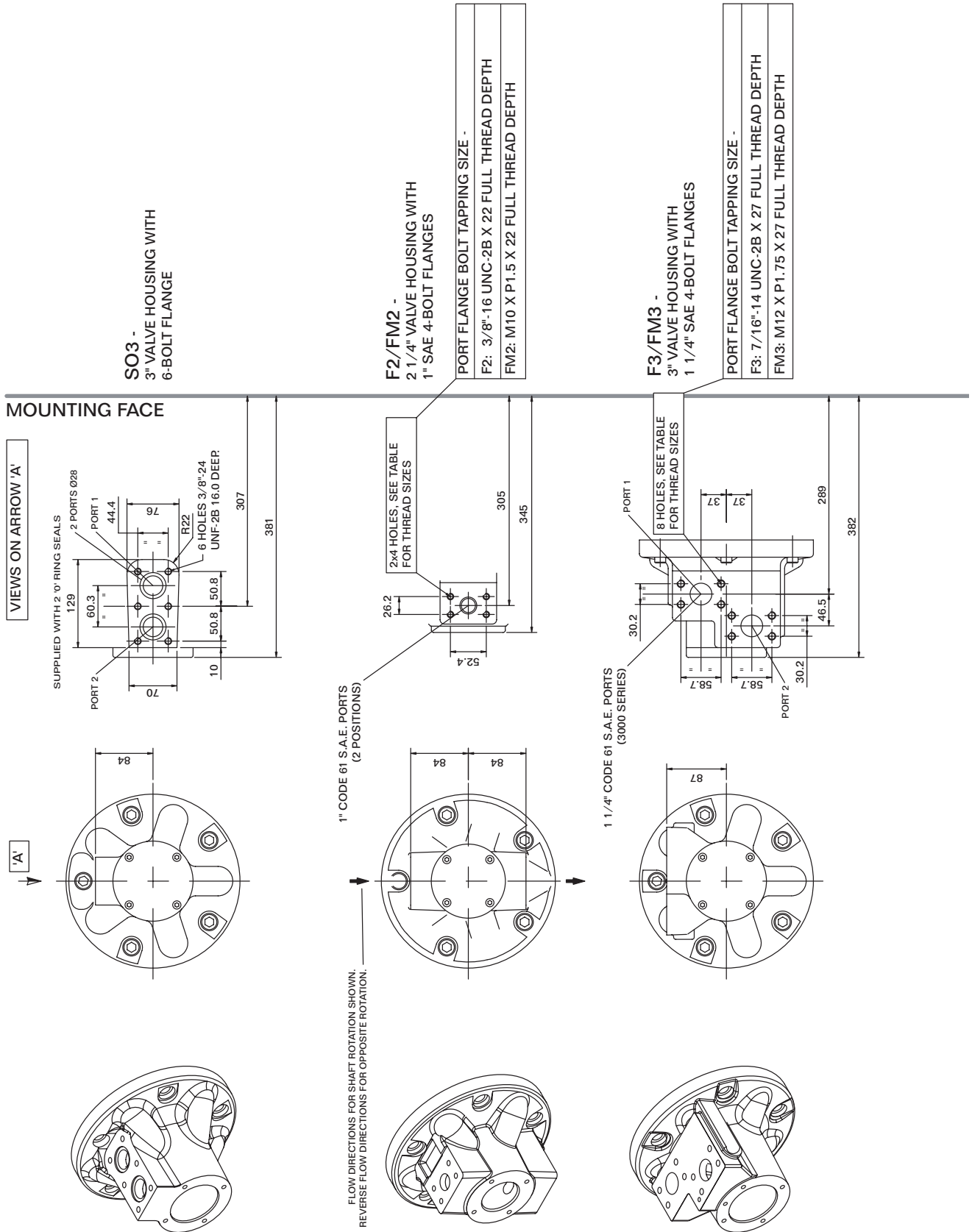

3/8" BSP x 17 FULL THREAD (CHOICE OF 3 POSITIONS) (2 NORMALLY PLUGGED)
 NOTE:- ENSURE ON INSTALLATION THAT DRAIN IS TAKEN FROM ABOVE MOTOR CENTRELINE.
 DO NOT EXCEED 12 DEPTH OF COUPLING IN TO DRAIN PORT

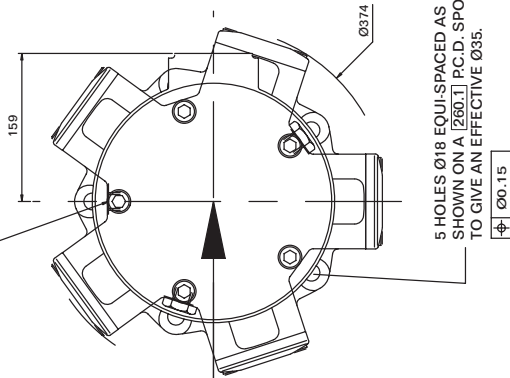

5 HOLES Ø18 EQUI-SPACED AS SHOWN ON A 260.1 P.C.D. SPOTFACED TO GIVE AN EFFECTIVE Ø35.
 ⌀ 0.15

REVERSE PORT CONNECTIONS FOR OPPOSITE DIRECTION OF SHAFT ROTATION
 FLOW DIRECTION FOR ALL VLV HSG VARIANTS EXCEPT F2/FM2

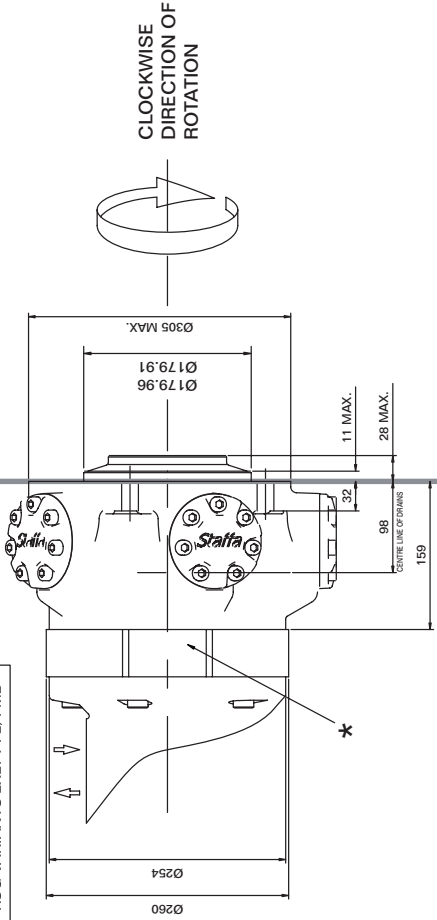

CLOCKWISE DIRECTION OF ROTATION

* SEE SEPARATE SHEETS FOR C-SPACER AND SHAFT VARIANTS

HMC045 installation

Example model code - HMC045/S/45/20/FM3/X/70

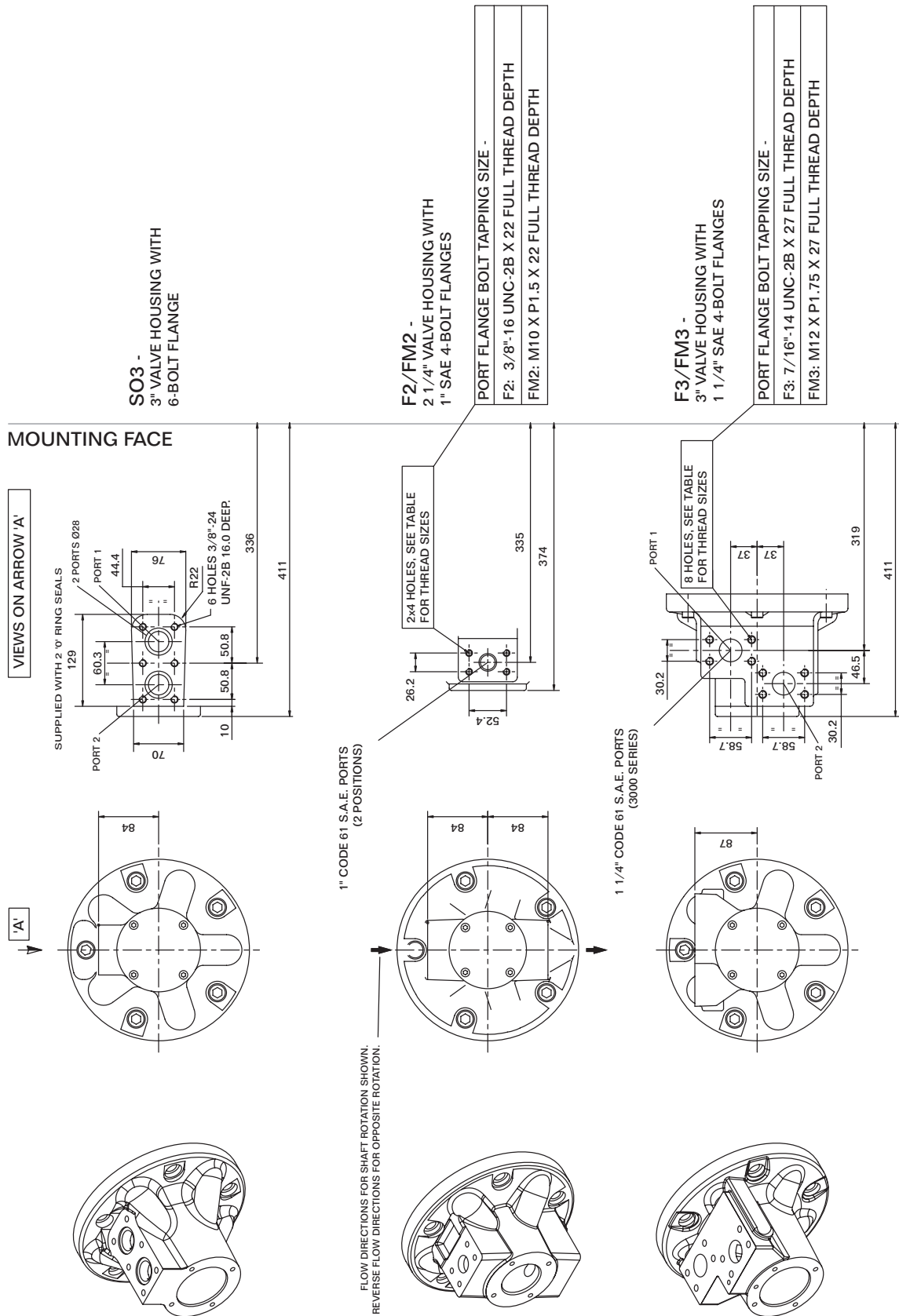

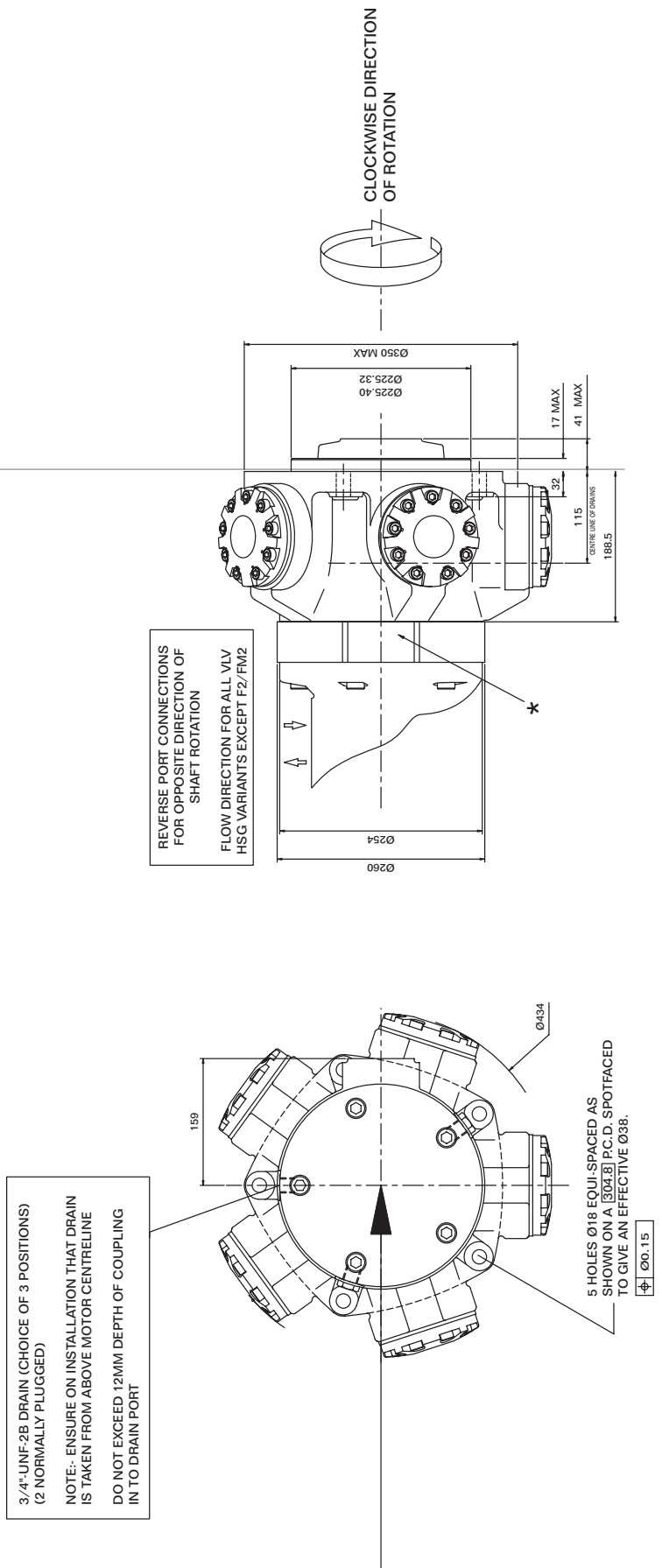

* SEE SEPARATE SHEETS FOR C-SPACER AND SHAFT VARIANTS

HMC080 installation

Example model code - HMC080/S/90/20/FM3/X/70

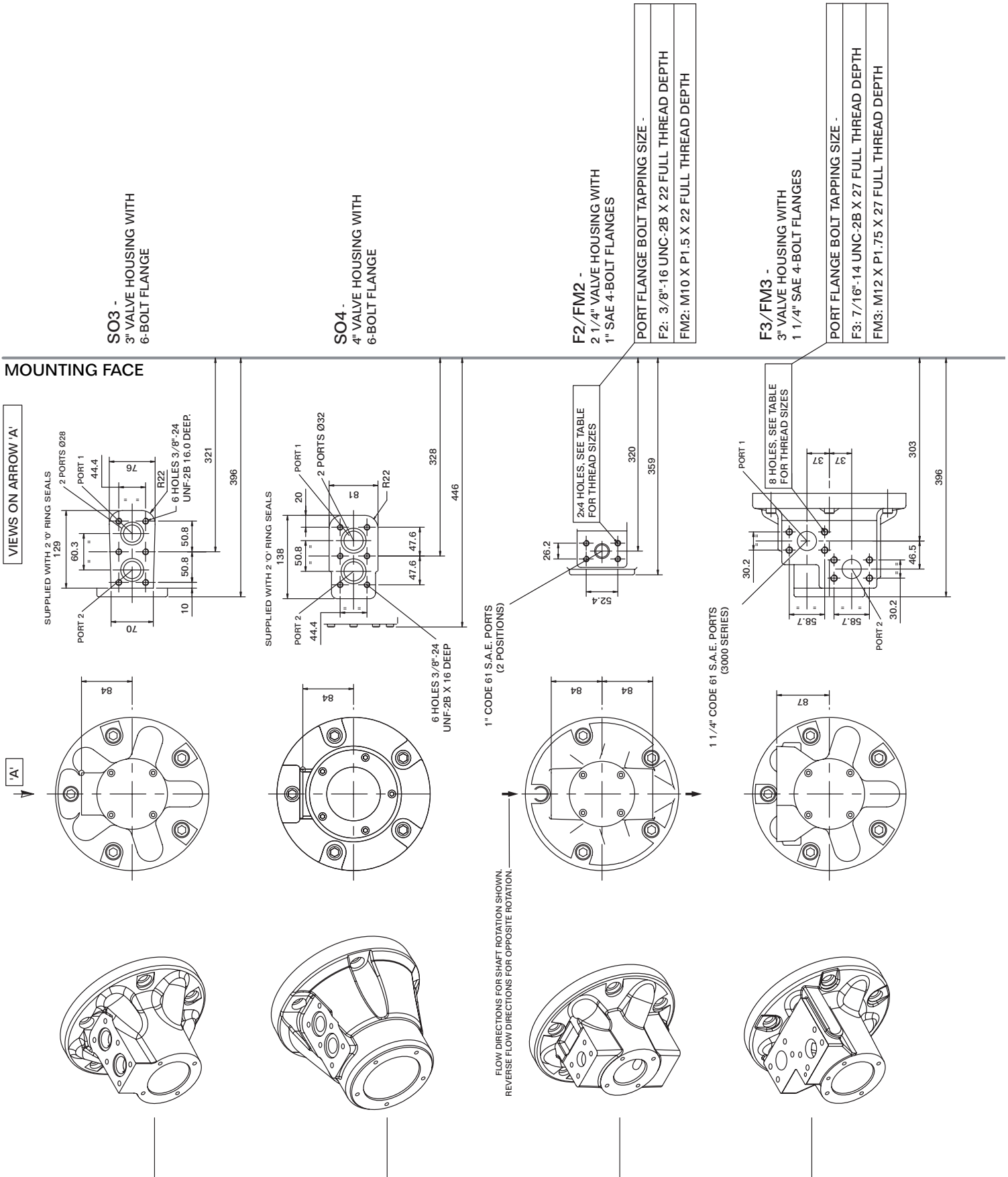

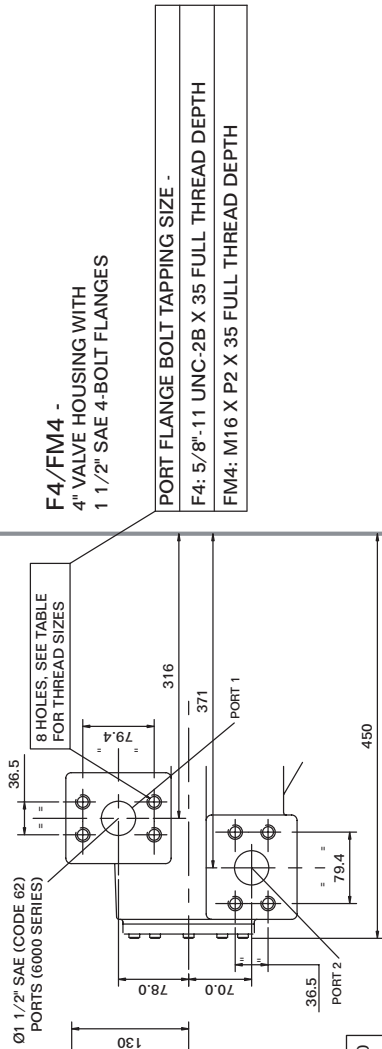

F4/FM4 -
4" VALVE HOUSING WITH
1 1/2" SAE 4-BOLT FLANGES

PORT FLANGE BOLT TAPPING SIZE -
F4: 5/8"-11 UNC-2B X 35 FULL THREAD DEPTH
FM4: M16 X P2 X 35 FULL THREAD DEPTH

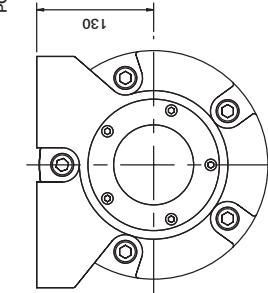

Ø1 1/2" SAE (CODE 62)
PORTS (6000 SERIES)

8 HOLES, SEE TABLE
FOR THREAD SIZES

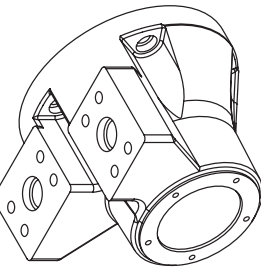

3/4"-16UNF-2B DRAIN (CHOICE OF 3 POSITIONS) (2 NORMALLY PLUGGED)
NOTE:- ENSURE ON INSTALLATION THAT DRAIN IS TAKEN FROM ABOVE
MOTOR CENTRELINE
DO NOT EXCEED 12mm DEPTH OF COUPLING IN TO DRAIN PORT

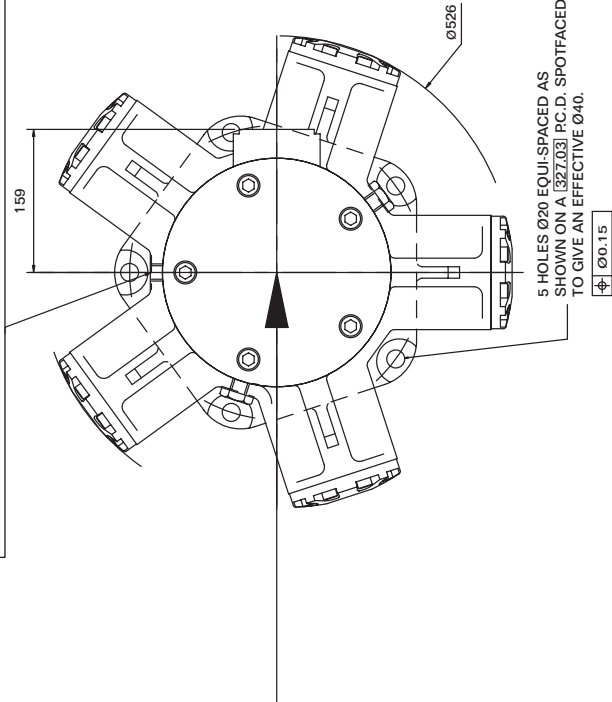

5 HOLES Ø20 EQUI-SPACED AS
SHOWN ON A [327.03] P.C.D. SPOTFACED
TO GIVE AN EFFECTIVE Ø40.

± Ø0.15

REVERSE PORT CONNECTIONS
FOR OPPOSITE DIRECTION OF
SHAFT ROTATION
FLOW DIRECTION FOR
ALL VLV HSG VARIANTS

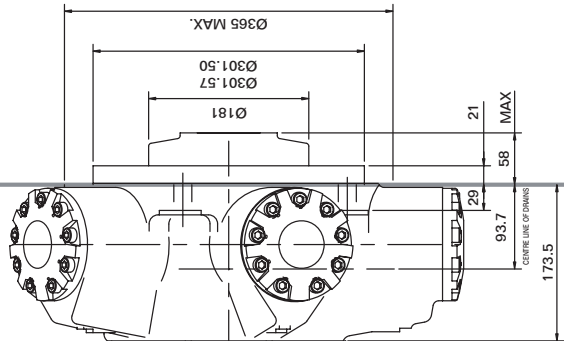

CLOCKWISE DIRECTION
OF ROTATION

* SEE SEPARATE SHEETS
FOR C-SPACER AND
SHAFT VARIANTS

HMC125 installation

Example model code - HMC125/S/125/100/FM3/X/70

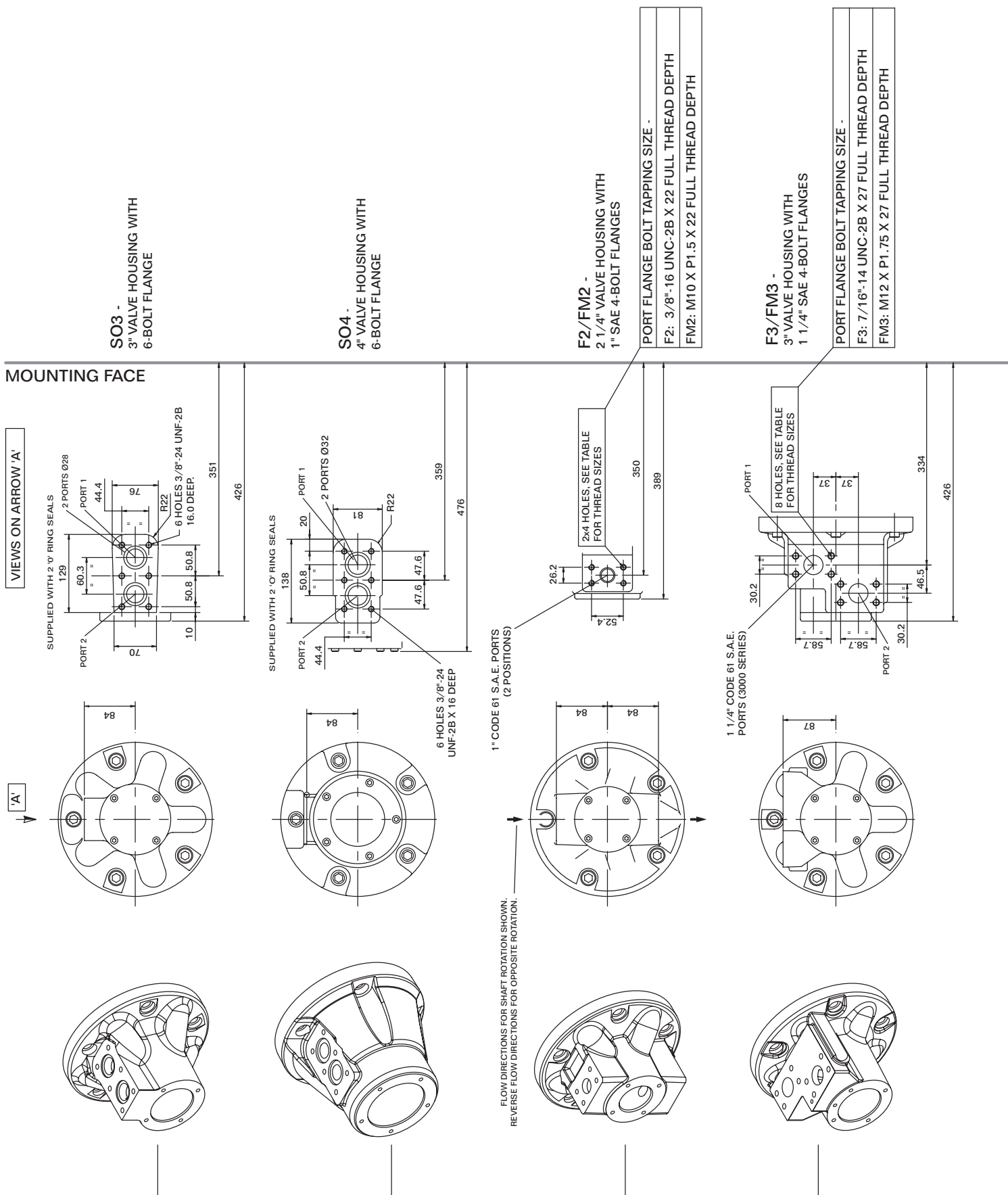

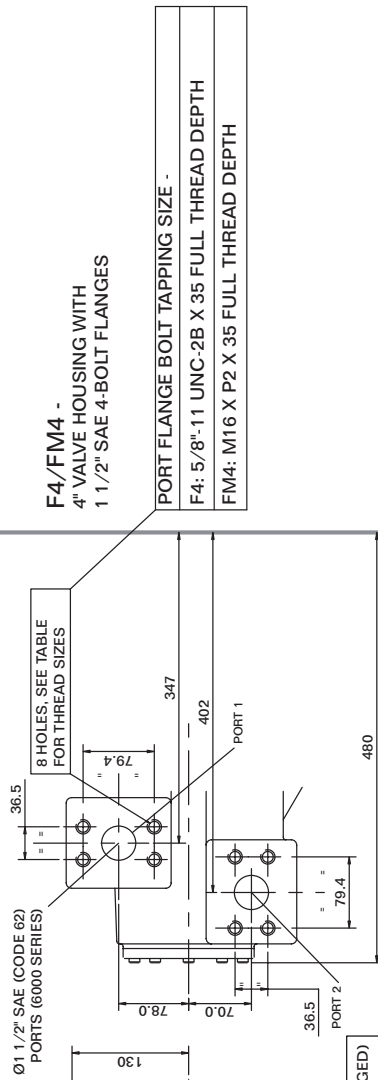

F4/FM4 -
4" VALVE HOUSING WITH
1 1/2" SAE 4-BOLT FLANGES

PORT FLANGE BOLT TAPPING SIZE -

F4: 5/8"-11 UNC-2B X 35 FULL THREAD DEPTH

FM4: M16 X P2 X 35 FULL THREAD DEPTH

Ø1 1/2" SAE (CODE 62)
PORTS (6000 SERIES)

8 HOLES, SEE TABLE
FOR THREAD SIZES

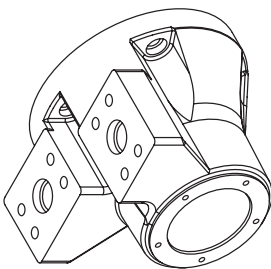
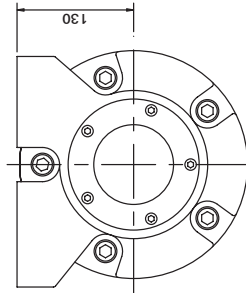

3/4"-16UNF-2B DRAIN (CHOICE OF 3 POSITIONS) (2 NORMALLY PLUGGED)

NOTE:- ENSURE ON INSTALLATION THAT DRAIN IS TAKEN FROM ABOVE
MOTOR CENTRELINE

DO NOT EXCEED 12mm DEPTH OF COUPLING IN TO DRAIN PORT

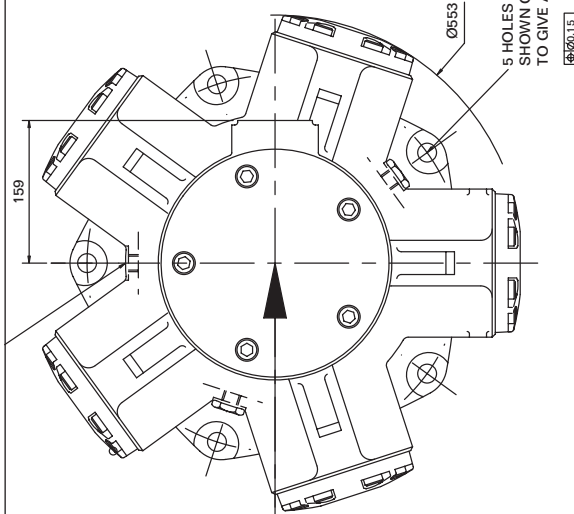

REVERSE PORT CONNECTIONS
FOR OPPOSITE DIRECTION OF
SHAFT ROTATION

FLOW DIRECTION FOR
ALL VLV HSG VARIANTS

Ø260
Ø254

* 5 HOLES Ø20 EQUI-SPACED AS
SHOWN ON ALEXTRIPCD. SPOTFACED
TO GIVE AN EFFECTIVE Ø40

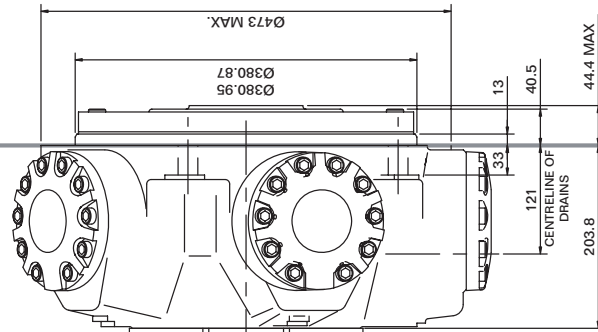

CLOCKWISE DIRECTION
OF ROTATION



* SEE SEPARATE SHEETS
FOR C-SPACER AND
SHAFT VARIANTS

HMC200 installation

Example model code - HMC200/S/180/60/FM3/X/70

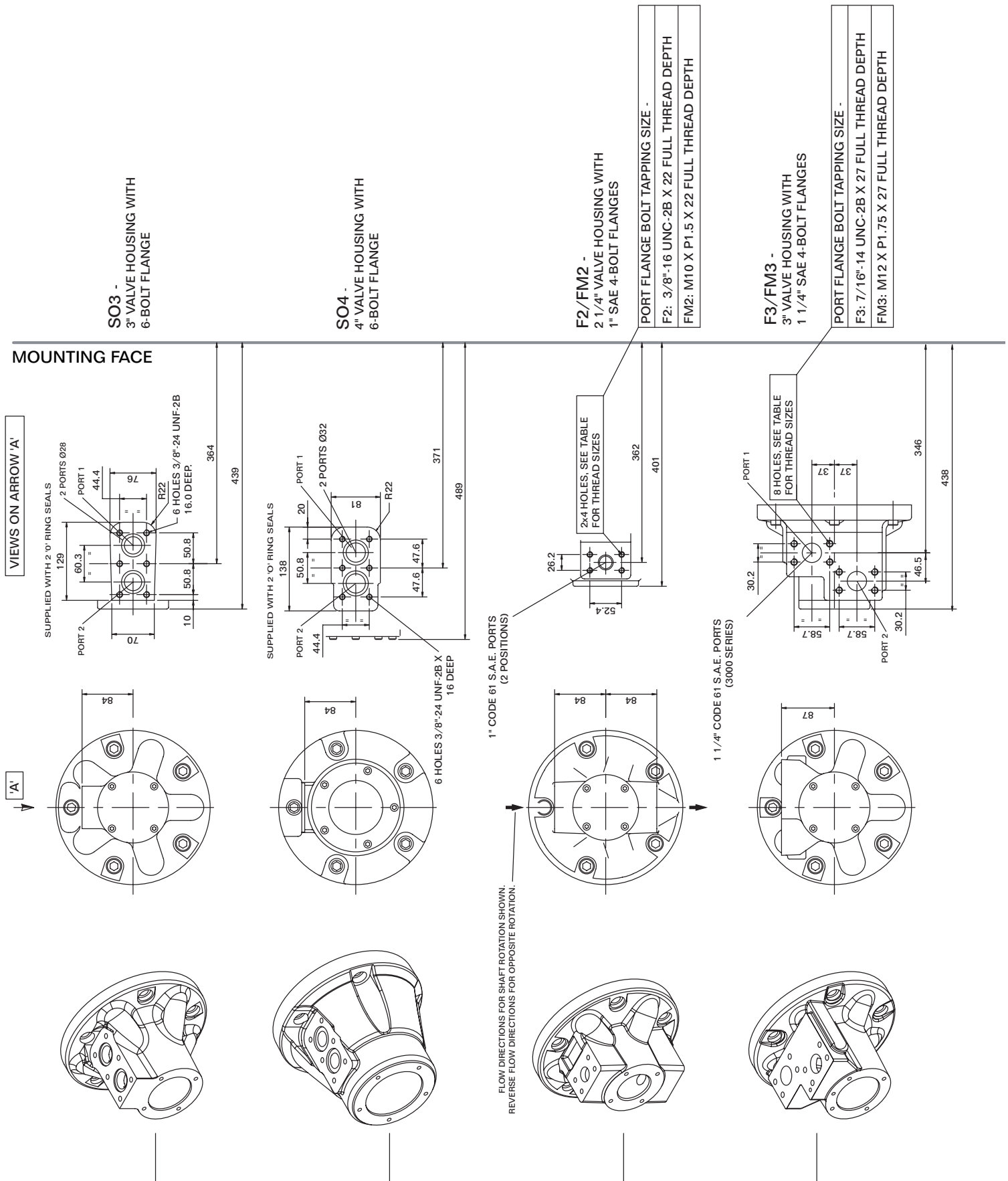

Ø1 1/2" SAE (CODE 62) PORTS (6000 SERIES)

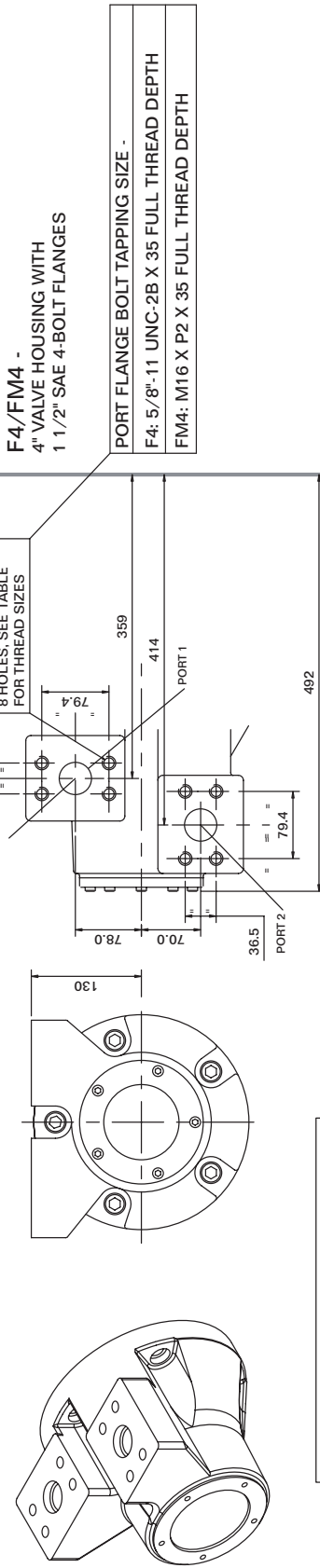

F4/FM4 -
4" VALVE HOUSING WITH
1 1/2" SAE 4-BOLT FLANGES

PORT FLANGE BOLT TAPPING SIZE -

F4: 5/8" - 11 UNC-2B X 35 FULL THREAD DEPTH

FM4: M16 X P2 X 35 FULL THREAD DEPTH

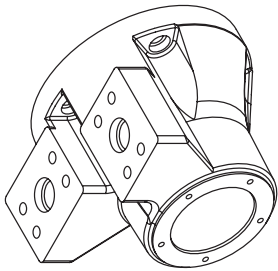

3/4"-16UNF-2B DRAIN (CHOICE OF 3 POSITIONS)
(2 NORMALLY PLUGGED)
NOTE:- ENSURE ON INSTALLATION THAT DRAIN
IS TAKEN FROM ABOVE MOTOR CENTRE LINE
DO NOT EXCEED 12mm DEPTH OF COUPLING
IN TO DRAIN PORT

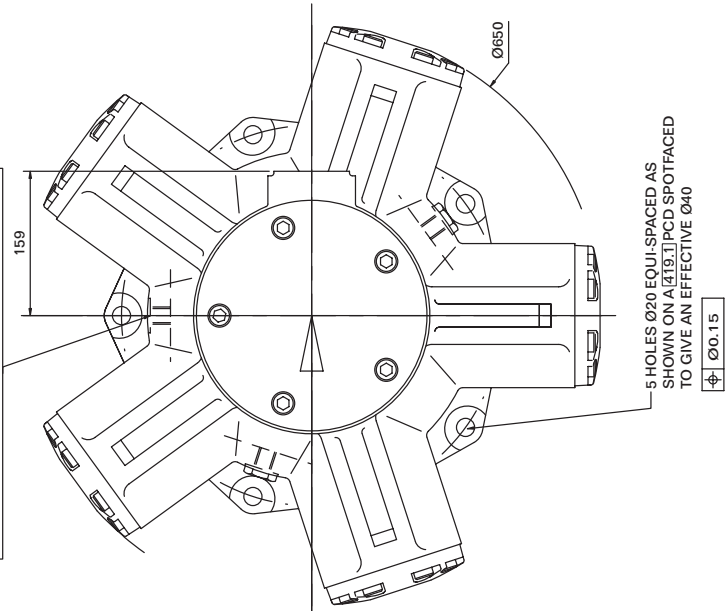

REVERSE PORT CONNECTIONS
FOR OPPOSITE DIRECTION OF
SHAFT ROTATION

FLOW DIRECTION FOR
ALL VLV HSG VARIANTS

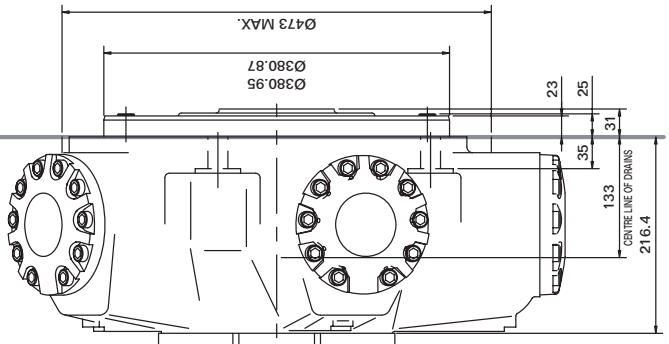

CLOCKWISE DIRECTION
OF ROTATION

* SEE SEPARATE SHEETS
FOR C-SPACER AND
SHAFT VARIANTS

HMC270 installation

Example model code - HMC270/S/280/60/FM4/X/70

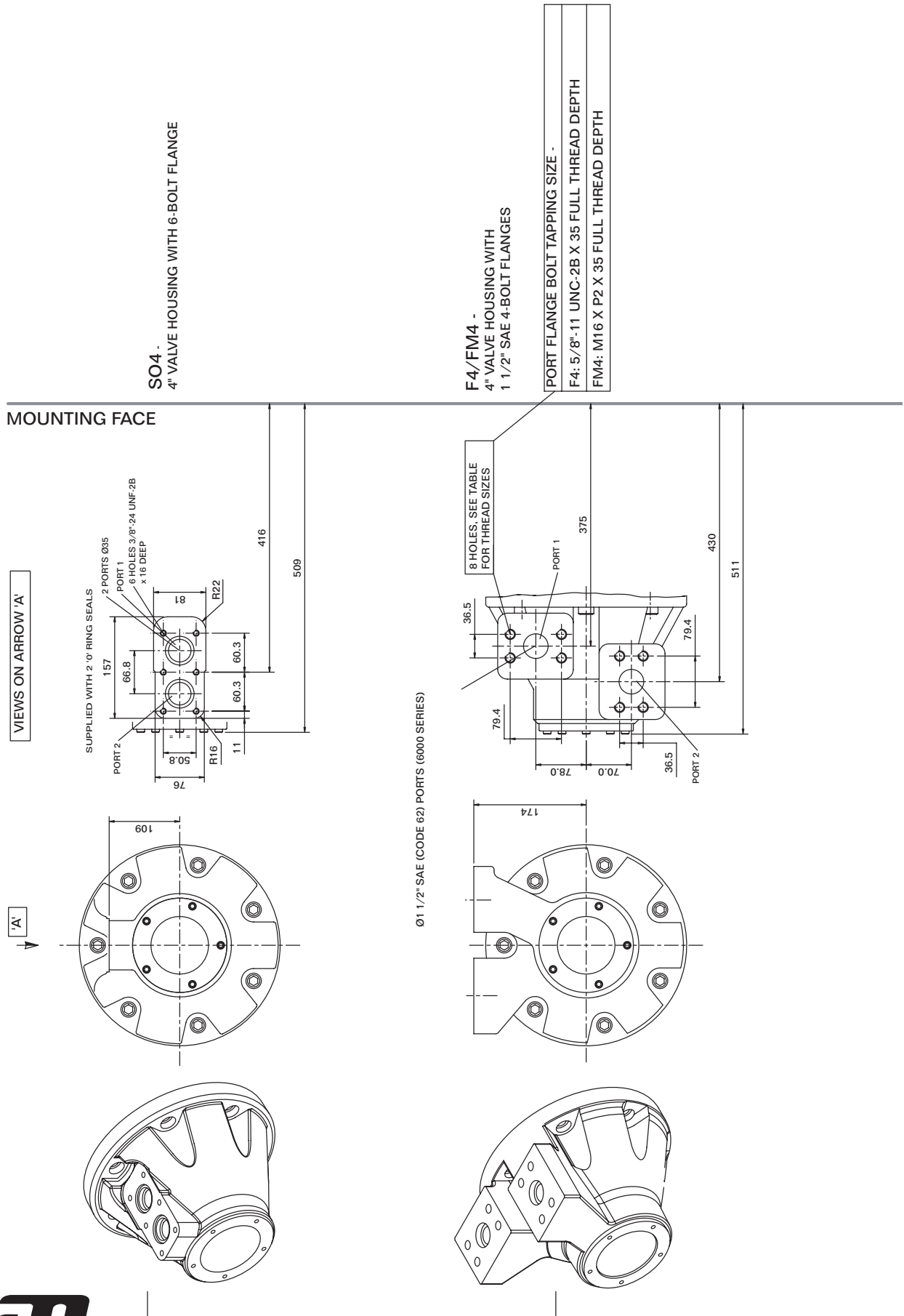

3/4"-16UNF-2B DRAIN (CHOICE OF 3 POSITIONS)
(2 NORMALLY PLUGGED)
NOTE:- ENSURE ON INSTALLATION THAT DRAIN
IS TAKEN FROM ABOVE MOTOR CENTRELINE
DO NOT EXCEED 12mm DEPTH OF COUPLING
IN TO DRAIN PORT

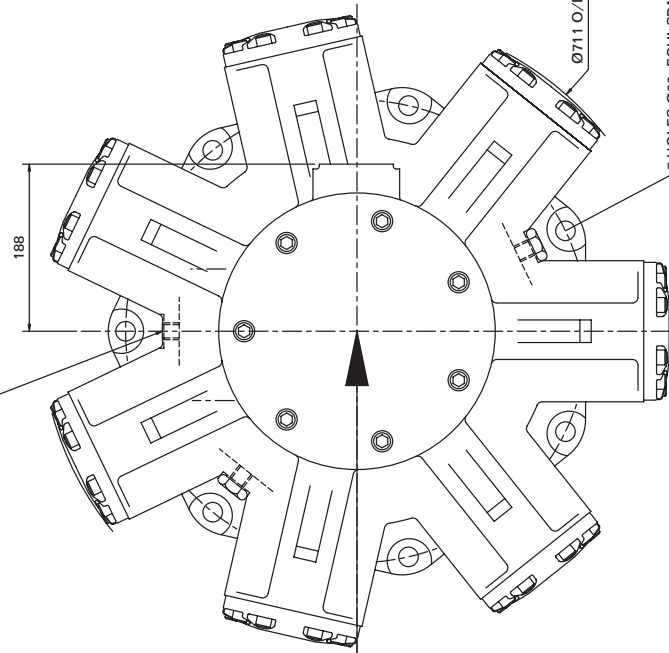

REVERSE PORT CONNECTIONS
FOR OPPOSITE DIRECTION OF
SHAFT ROTATION
FLOW DIRECTION FOR
ALL VLV HSG VARIANTS

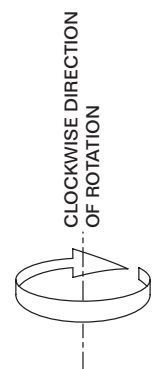
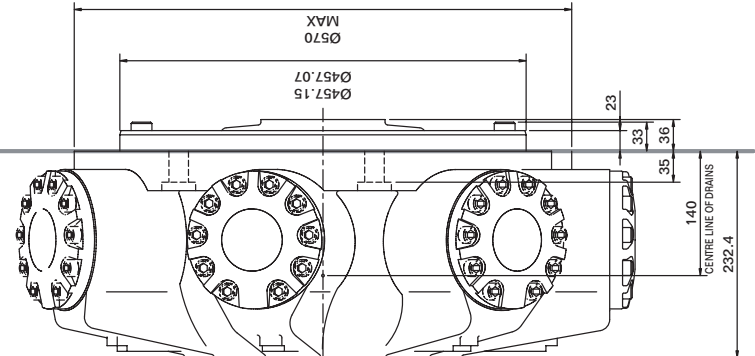
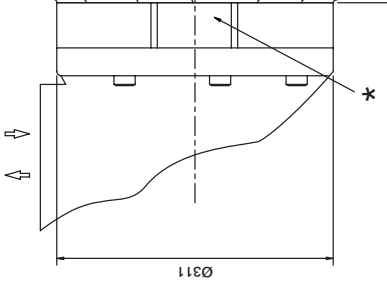

* SEE SEPARATE SHEETS
FOR C-SPACER AND
SHAFT VARIANTS

HMC325 installation

Example model code - HMC325/S/300/60/FM4/X/70

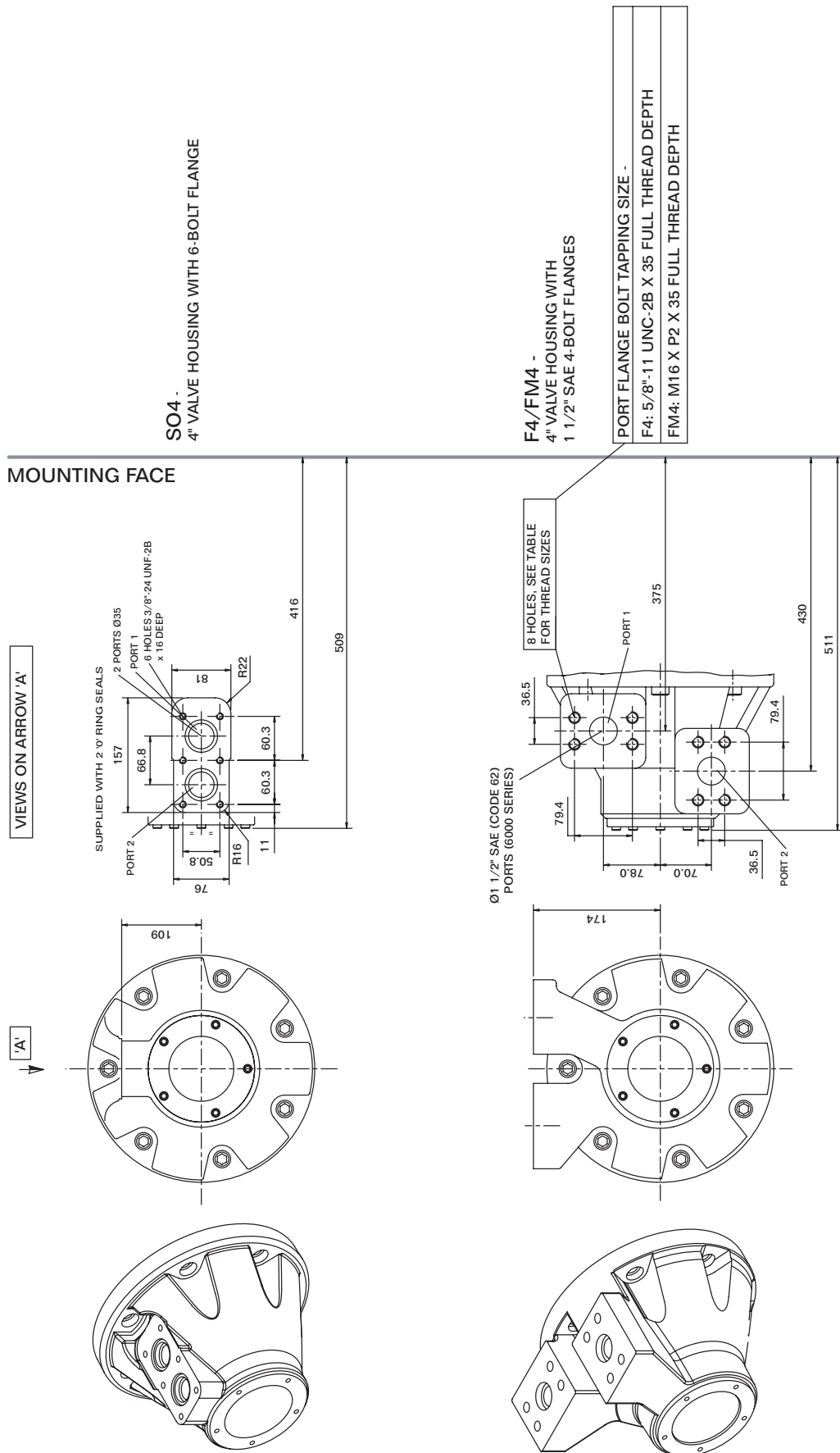

3/4"-16UNF-2B DRAIN (CHOICE OF 3 POSITIONS)
(2 NORMALLY PLUGGED)
NOTE:- ENSURE ON INSTALLATION THAT DRAIN
IS TAKEN FROM ABOVE MOTOR CENTRELINE
DO NOT EXCEED 12mm DEPTH OF COUPLING
IN TO DRAIN PORT

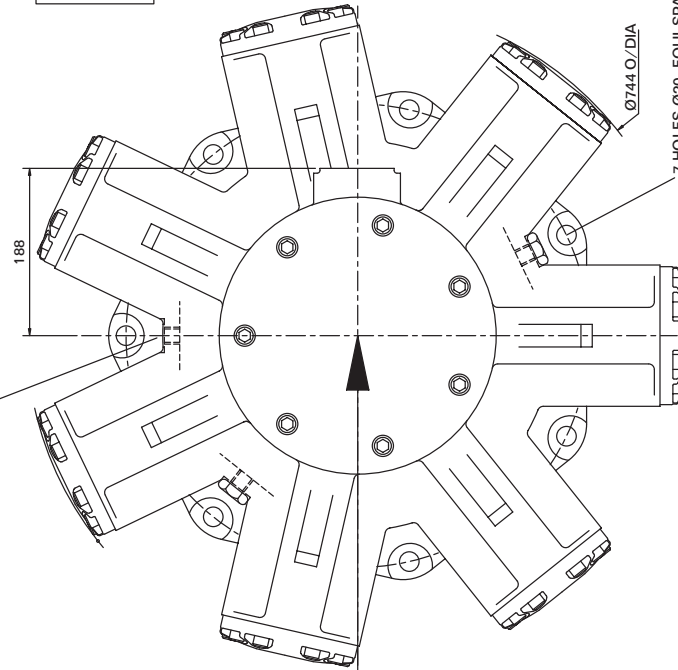

REVERSE PORT CONNECTIONS FOR OPPOSITE DIRECTION OF SHAFT ROTATION

FLOW DIRECTION FOR ALL VLV HSG VARIANTS

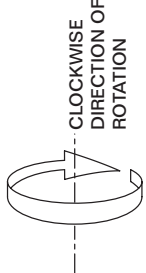
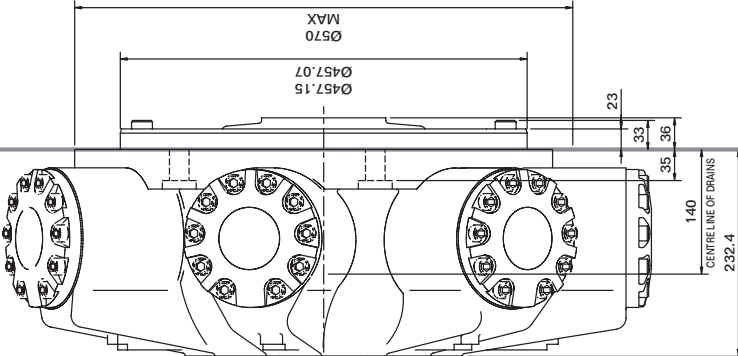

* SEE SEPARATE SHEETS FOR C-SPACER AND SHAFT VARIANTS

Product type

HMC030	=	As per HMC045
HMC045		
F2	=	1" SAE 4-bolt UNC flange
FM2	=	1" SAE 4-bolt metric flange
SO3	=	Staffa 3" 6-bolt flange
F3	=	1 1/4" SAE 4-bolt flange
FM3	=	1 1/4" SAE 4-bolt flange
HMC080		
SO3	=	Staffa 3" 6-bolt flange
SO4	=	6-bolt UNF flange Staffa original valve housing
F3	=	1 1/4" SAE 4-bolt flange
FM3	=	1 1/4" SAE 4-bolt flange
F4	=	SAE 1 1/2" 4-bolt UNC flanges
FM4	=	SAE 1 1/2" 4-bolt metric flanges
HMC125		
SO3	=	Staffa 3" 6-bolt flange
SO4	=	6-bolt UNF flange Staffa original valve housing
F3	=	1 1/4" 3000 series SAE 4-bolt flange
FM3	=	1 1/4" 3000 series SAE 4-bolt flange
F4	=	SAE 1 1/2" 4-bolt UNC flanges
FM4	=	SAE 1 1/2" 4-bolt metric flanges
HMC200		
SO3	=	Staffa 3" 6-bolt flange
SO4	=	6-bolt UNF flange Staffa original valve housing
F3	=	1 1/4" SAE code 61 4-bolt flange
FM3	=	1 1/4" SAE code 61 4-bolt flange
F4	=	SAE 1 1/2" 4-bolt UNC flanges
FM4	=	SAE 1 1/2" 4-bolt metric flanges
HMC270		
SO4	=	Staffa 4" 6-bolt flange
F4	=	1 1/2" SAE code 62 4-bolt flange
FM4	=	1 1/2" SAE code 62 4-bolt flange
HMC325		
SO4	=	Staffa 4" 6-bolt flange
F4	=	1 1/2" SAE code 62 4-bolt flange
FM4	=	1 1/2" SAE code 62 4-bolt flange

HOG 71 - encoder

TO SUIT: F3/FM3/SO3

'Th'

TO SUIT: F4/FM4/SO4

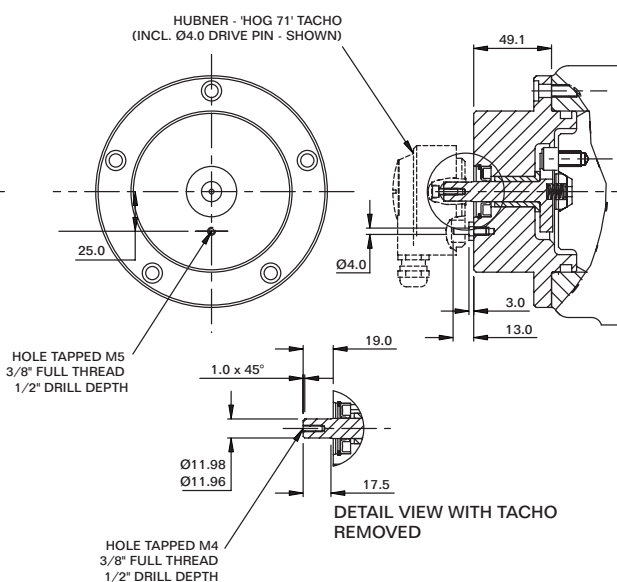
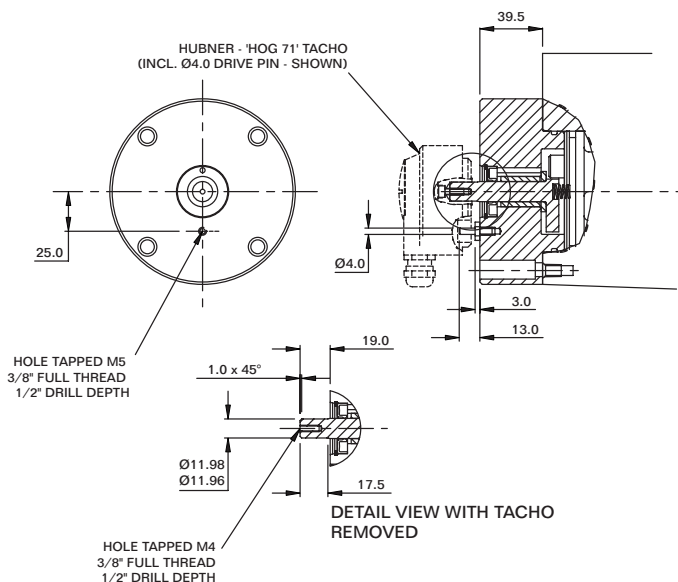

Model code:

HOG71 DN 1024 TTL

IP66

Power supply: 5V @ 100 mA

Output signal: Two TTL signals displaced by 90 deg. plus maker and inverted signals

Model code:

HOG71 DN 1024 HTL

IP66

Power supply: 9 TO 26V @ 100 mA

Output signal: As per TTL but with HTL signals

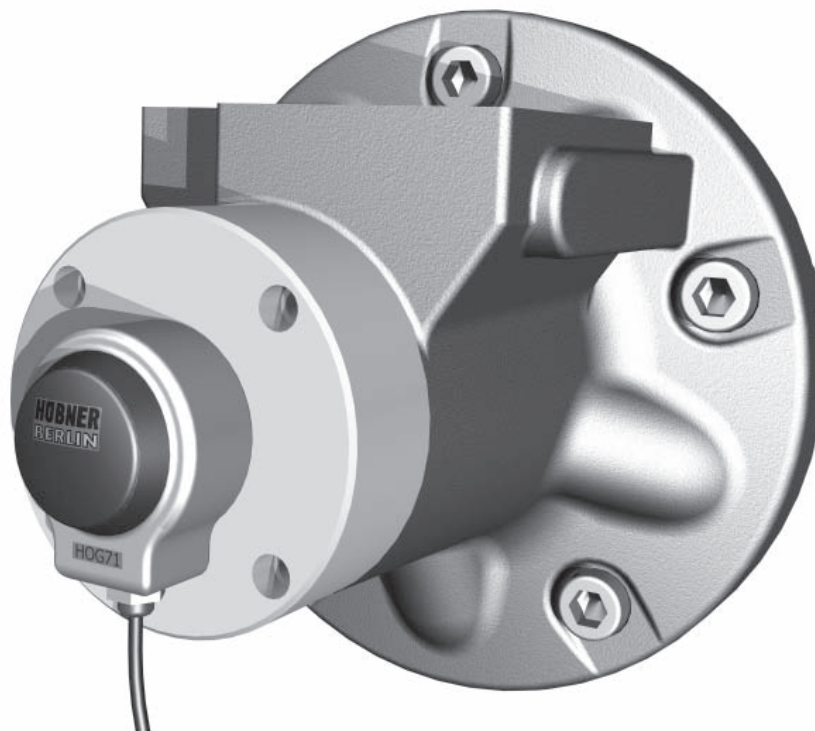

Note: Speed sensors should be ordered as a separate item from Hubner.

GTB 9 - tacho

TO SUIT: F3/FM3/SO3

'Tg'

TO SUIT: F4/FM4/SO4

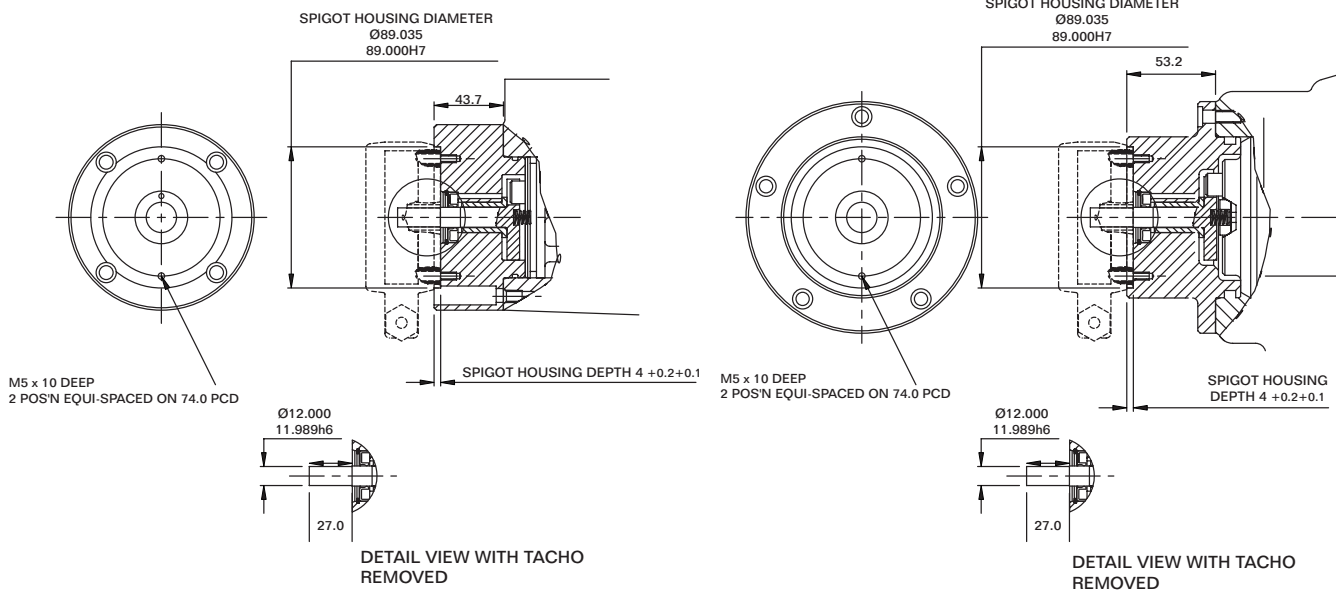

Model code:
 GTB9.06 L 420
 IP68
 Output signal: 20V/1000 rpm

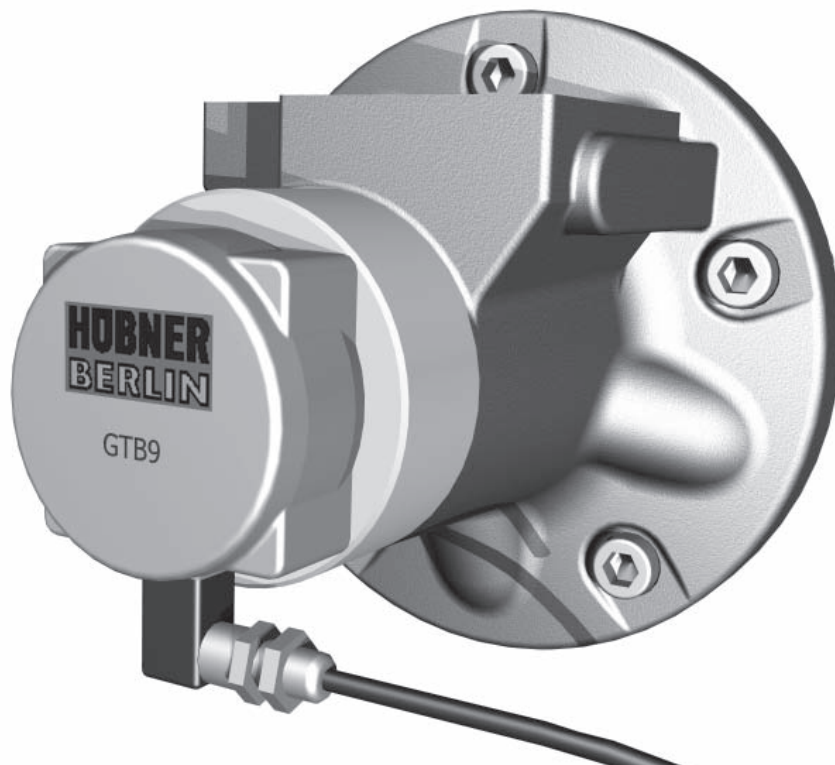

Note: Speed sensors should be ordered as a separate item from Hubner.

Tj speed sensor with Tk option

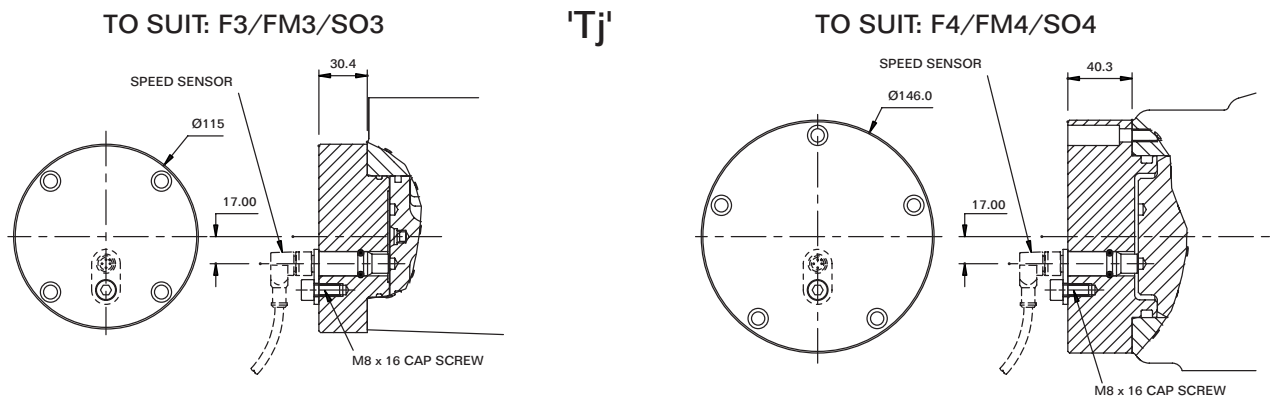

Technical specification:

- Description: Hall effect dual channel speed probe
- Signal outputs: Square wave plus direction signal
- Power supply: 8 to 32V @ 40 mA
- Protection class: IP68
- Output frequency: 16 pulses/revolution

Tj speed probe and Tk optional T401 module. See model code detail on page 57. The T401 is software configured for both speed calibration and relay speed trip setting.

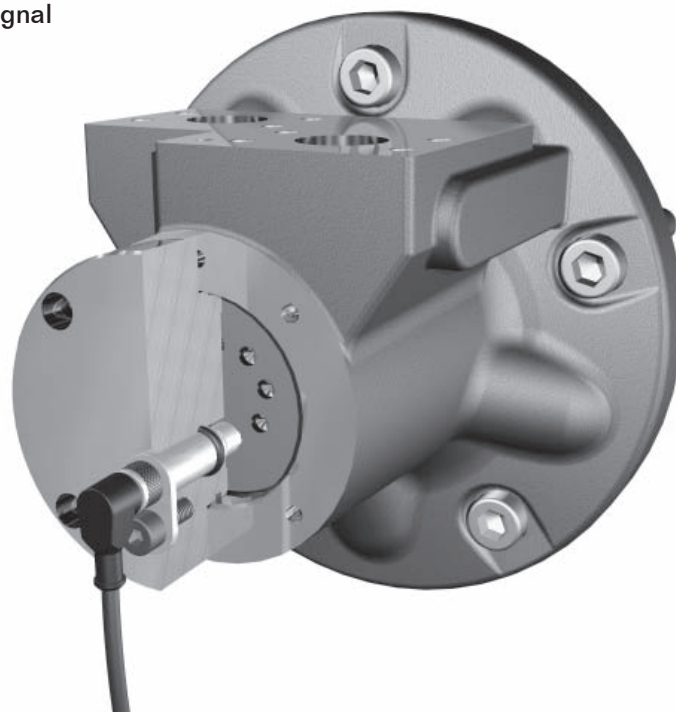

Tj cable assembly

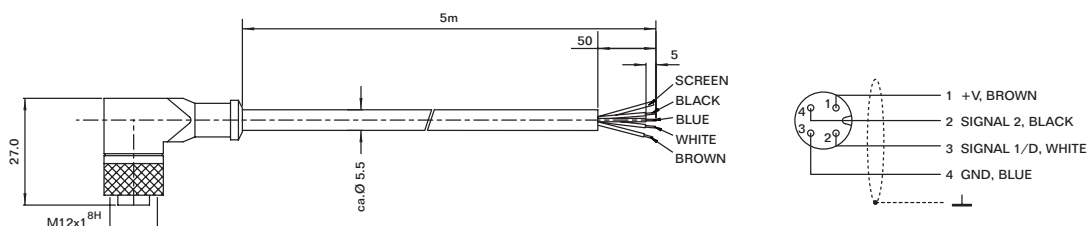

HMC series motor

F11 **HM** **C125** **S** **V** **125** **70** **FM3** **CS** **Tj** **70** **MO** **PL******

Fluid type

(refer to page 3 for performance data)

Blank: Mineral oil.

F3: Phosphate ester (HFD fluid).

F11: Water-based fluids (HFA, HFB & HFC).

Alternative fluids contact Kawasaki Precision Machinery UK Ltd. Nominate fluid type and make on order.

Model type

HM: Standard

HMHD: Heavy Duty

Motor frame size

C030	C125	C325
C045	C200	
C080	C270	

Shaft type

See shaft type option list on pages 33 to 38

Shaft

Vertically up

High displacement code

See displacement code details on pages 4 to 10

Main port connections

See port connection details on pages 4 to 10

Main port connections

See port connection details on page 53

Displacement control ports (pages 14 to 15)

Threaded ports/bi-directional shaft rotation:

X: X and Y ports G $\frac{1}{4}$ " (BSPF to ISO 228/1).

ISO 4401 size 03 mounting face/bi-directional shaft rotation:

C: No shuttle.

CS: With shuttle valve (see options by product type).

ISO 4401 size 03 mounting face/uni-directional shaft rotation (viewed on shaft end):

C1: Control pressure from main port 1 (shaft rotation clockwise with flow into port 1).

CP18: CP valve set to 180 bar

CHP18: CP valve set to 180 bar with override valve attached (see page 18).

Please state CP valve setting when placing an order and note that the maximum setting is 220 bar, i.e. CP22.

See page 16 to 18 for CP valve description and options.

Special features

PL**:**

Non-catalogued features, (****)= number assigned as required.

eg:

High pressure shaft seals.
Alternative port connections.
Stainless steel shaft sleeves.
Alternative encoder and tacho drives.
Motor valve housing orientation.
Special paint.

Leave blank if not required

- M0:** CETOP3 Interface for low speed applications with crossline reliefs and make-up checks.
- M1:** Dual crossline relief valve with make-up checks for a FM3 valve assembly (rated flow: 380 lpm).
- M2:** Single counterbalance valve with make-up checks for a FM3 valve assembly (rated flow: 480 lpm).
- M3:** Dual counterbalance valve with make-up checks for a FM3 valve assembly (rated flow: 480 lpm).
- M4:** Remote pilot operated load control valve with make-up checks for a FM3 valve assembly (rated flow: 480 lpm).
- M5:** Dual crossline relief valve with make-up checks for a FM4 valve assembly (rated flow: 760 lpm).
- M6:** Single counterbalance valve with make-up checks for a FM4 valve assembly (rated flow: 480 lpm).
- M7:** Dual counterbalance valve with make-up checks for a FM4 valve assembly (rated flow: 480 lpm).
- M8:** Dual counterbalance valve with make-up checks for a FM4 valve assembly (rated flow: 960 lpm).
- M9:** Remote pilot operated load control valve with make-up checks for a FM4 valve assembly (rated flow: 480 lpm).

Notes: All crossline relief valves will be set to 270 bar unless otherwise requested.
Soft start relief valves can be ordered on request.
Further technical detail can be seen by visiting: www.sunhydraulics.com.

Design number

Tacho/Encoder drive - Leave blank if not required

- Tj:** Square wave output with directional signal.
- Tk:** Combines Tj with the T401 instrument to give a 4 to 20 mA output proportional to speed, directional signal and speed relay output.
- Th:** Encoder system with a pulsed frequency output proportional to speed.
- Tg:** Tachogenerator with a D.C. output signal proportional to speed.

**KAWASAKI PRECISION
MACHINERY (UK) LTD**
Ernesettle, Plymouth,
Devon, PL5 2SA, England

Tel: +44 1752 364394

Fax: +44 1752 364816

Mail: info@kpm-uk.co.uk

Website: www.kpm-eu.com

The specified data is for product description purposes only and may not be deemed to be guaranteed unless expressly confirmed in the contract.

All rights reserved, subject to revision.

Data sheet: M-1004/07.07